

# INSTALLATION GUIDE



## Outback® Flat Attached WITH COOLDEK® ROOFING



### BEFORE YOU START

It is important to check your Local Government Authority requirements before the installation of your new Stratco Outback® with Cooldek Flat Verandah. It is the builder's responsibility to ensure any existing structure that an Outback is being attached to is adequately reinforced to accommodate the additional loads imposed by the verandah, patio or carport. Read these instructions thoroughly before starting your project and refer to them constantly during each stage of construction. Contact Stratco for advice if you do not have the necessary tools or information.

Before starting, lay out the main components in order of assembly on the ground and check them against the delivery note. The 'Components' section identifies each part of your Outback Flat Verandah with Cooldek and shows the relative location of the components.

Mark out the overall area of your verandah, patio or carport and ensure that it is free from obstructions. Beam to wall connections can cause difficulty if they coincide with windows and door openings, so avoid these in your design. Ensure there is reasonable access for materials and working space and consider the disposal of run-off water. Check the column and beam positions on the ground; roughly check they are square by measuring the diagonals, then mark out the column locations. If columns are to be 'in ground', dig the holes to Stratco specifications.

### ADDITIONAL MATERIALS







The Outback kit does not include fixings to attach the unit to an existing structure or concrete/masonry anchors for the column installation. If required, they must be purchased as additional items.

### TOOLS REQUIRED

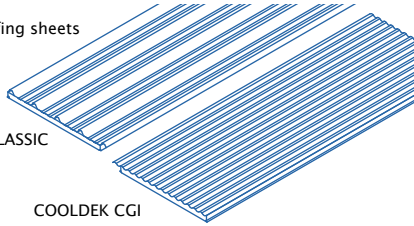
- |   |   |   |
|---|---|---|
| <ul style="list-style-type: none"><li>• Drill &amp; Hex head Adaptor (5/16 &amp; 3/8)</li><li>• Rivet Gun</li><li>• Tape Measure</li><li>• Tin Snips</li><li>• Spirit Level</li></ul> | <ul style="list-style-type: none"><li>• Hack-Saw</li><li>• Post Hole Digger</li><li>• Silicone Gun</li><li>• Spanner or Ratchet</li><li>• Adjustable Construction Props</li></ul> | <ul style="list-style-type: none"><li>• Turn Up/Down Tool</li><li>• Concrete</li><li>• Ladder</li></ul> |
|---|---|---|

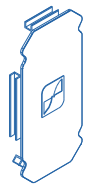
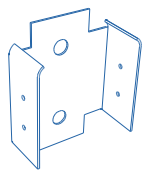
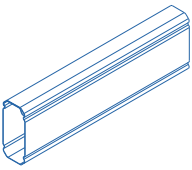
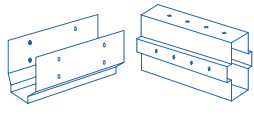
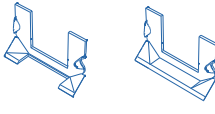
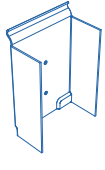
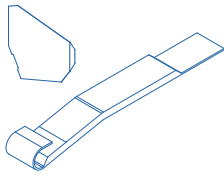
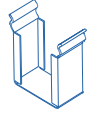

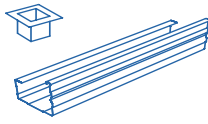
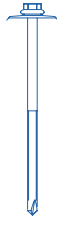
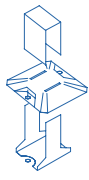
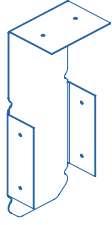
# COMPONENTS

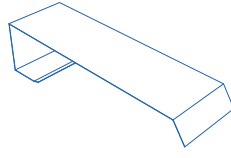
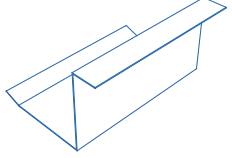
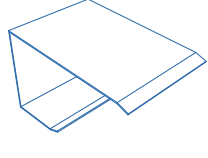
<p><b>COOLDEK</b> Insulated Roofing sheets</p>  <p>COOLDEK CLASSIC COOLDEK CGI</p>	<p><b>COLUMNS</b> Support the beam framework.</p> 	<p><b>BEAM END CAP</b> Encloses the end of the beam.</p> 	<p><b>WALL BRACKET</b> Fastens the Outback beams directly to a wall.</p> 	
<p><b>OUTBACK BEAMS</b> The beams are the frame to support the roofing.</p> 	<p><b>BEAM INLINE CONNECTORS</b> Joins beams flush to form a continuous beam. Different connectors are available for various angles and loadings.</p> 	<p><b>BEAM FILLERS</b> Fills gap between intersecting beams. A notched version is available where a column also intersects.</p> 	<p><b>BEAM TO BEAM BRACKET</b> Connects horizontal beams.</p> 	<p><b>GUTTER STRAP AND STOP END</b></p> 
<p><b>POST BRACKET</b> Connects post to beam.</p>  <p><b>POST CAP</b> Fills the gap between the post and beam.</p> 	<p><b>GUTTER</b> The gutter adjoins the roof to catch water run off. Stop ends, outlets, straps and brackets are available.</p> 	<p><b>TEK SCREWS WITH CYCLONE CAP AND NEOPRENE WASHER</b> Used to fix insulated deck into beams.</p> 	<p><b>FOOTING PLATES</b> 68 Outback column footing plate.</p> 	<p><b>SUSPENSION BRACKET</b> Replaces the wall brackets when the beam is suspended from the fascia.</p> 
<p><b>DOWNPIPE</b> Funnels water from the gutter to the ground via an outlet. Accessories of mitres, shoes and brackets are available as optional extras.</p> 	<p><b>SCREWS AND RIVETS</b> Fastener types vary depending upon the connection, ensure the correct fixings are used.</p> 	<p><b>SIDE CAP FLASHING</b></p> 	<p><b>CUTBACK FLASHING</b></p> 	<p><b>BACK CHANNEL</b></p> 

# FLASHING LAYOUT

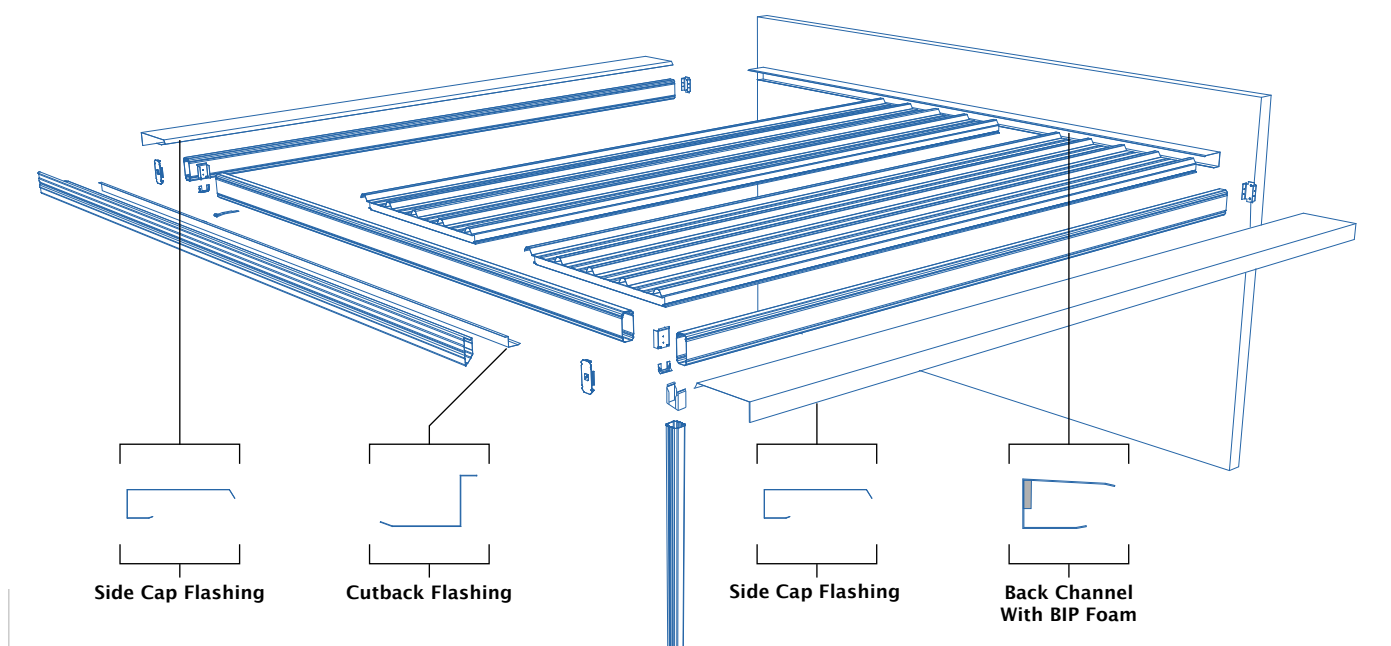

# BACK CHANNEL INSTALLATION

## Back Channel

The shorter edge of the back channel is the underside. The back channel should run from the outside edges of the side beams. If multiple lengths are required, butt the channels together and waterproof with silicone.

Determine what type of fascia you are attaching your unit to and what type of fixings and brackets you require. Pre-drill the back channel on the ground.

Locate the first hole 100mm from the edge of the back face of each length of channel. Drill the other holes at 500mm centres for brickwork or 250mm centres for steel and timber fascia. Run two beads of silicone along the back of the back channel, with one near the top edge to ensure a water tight seal.

## Fascia Attachment

When fixing the back channel to fascia, the roofing above each rafter must be removed to give adequate space to install the fascia strengthening brackets. M10 Bolts connect the brackets to the rafter and fascia (the number of brackets required is determined by the builder, but the spacing should not exceed 1200mm). Silicone as shown in the diagrams. When fixing to timber fascia (Figure 1.0) attach the back channel using 12x25mm hex head timber fixing screws through the pre-drilled holes. When fixing to steel fascia (Figure 1.2) attach the back channel using 12x20mm hex head self drilling screws through the pre-drilled holes. The back channel is bolted through the fascia to the fascia brackets with one M10 bolt per bracket. Insert BIP foam into the top half of the back channel, this acts as a weather seal when the roof sheets are pressed into it.

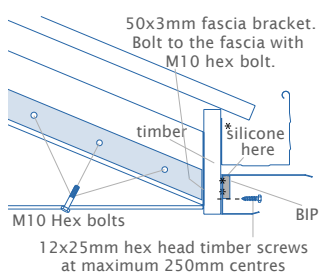

Figure 1.0

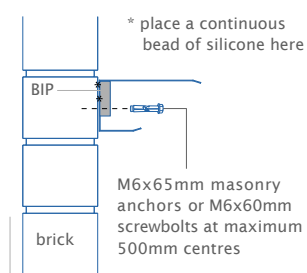

Figure 1.1

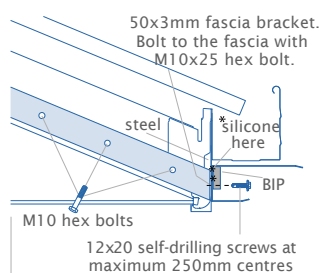

Figure 1.2

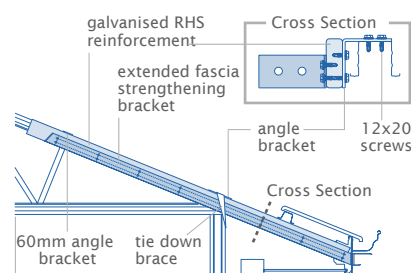

Figure 1.3

## Attaching to a Brick Wall

When fixing the back channel to a brick wall, pre-drill the anchor holes using a masonry drill bit. Attach the back channel using M6x65mm masonry anchors through the pre-drilled holes (Figure 1.1). Insert the BIP foam into the back channel, this acts as a weather seal when the roof sheets are pressed into it.

## Steel House Frame Attachment

When fixing the back channel to the steel fascia on a steel framed house, the roofing above each rafter must be removed to allow enough room to install the rafter strengthening brackets.

Attach angle brackets to 75x25x1.6mm RHS reinforcement using 12x20 self drilling screws. Place the brackets above the first web or truss connection at least 900mm from the wall, and directly over the wall. Fasten with four 12x20 self drilling screws to the chord or rafter (Figure 1.3).

Attach the extended fascia strengthening bracket to the reinforcing RHS using 12x20 self drilling screws at 200mm centres. It is the builder's responsibility to determine the adequacy of the fascia and rafters and the frequency of the brackets for each individual situation.

For added strength, fix a tie down brace to the adjacent studs. Use two 12x20 self drilling screws to fix the tie down to the top chord, and on each stud use two 12x20 self drilling screws on either side of the truss or rafter. Fix the back channel to the fascia as previously described.

# BRACKETS

## Wall Bracket

For units attached to a wall, position the wall brackets where the beams meet the wall. The folded section on the tabs of the bracket is located at the top. The highest point of the wall bracket will be 15mm below the top of the beam. Mark the holes and drill using an 8mm masonry bit. Fasten the bracket to the wall with two M8 masonry anchors to a minimum 65mm embedment. The beam is slid into position and fastened with four 12x20 self drilling screws (Figure 2.0). Back channel not shown.

## Suspension Bracket

A suspension bracket is used when a beam is suspended from the fascia. The top tab of the bracket must be located between the fascia and the back channel. Use silicone to seal behind the suspension bracket and fascia. For steel fascia a minimum of three 12x20 hex head screws are fixed through the back channel, suspension bracket and fascia. For timber, three 12x25 type 17 screws are used to fix through the back channel, suspension bracket and timber. The beam is slid into position and fastened using four 12x20 self drilling screws (Figure 2.1).

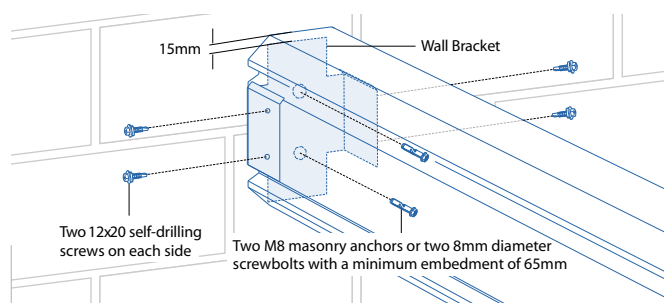

Figure 2.0

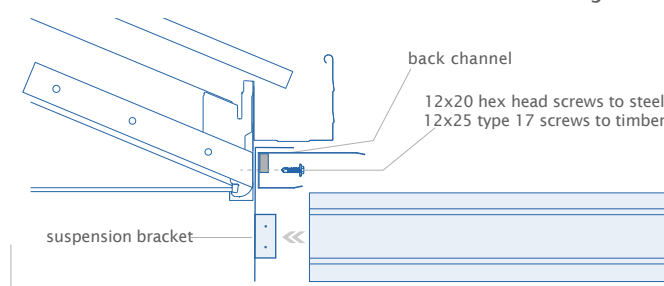

Figure 2.1

# BEAMS

## End Fascia Beam

When installing all beams, ensure the double thickness of the beam is on top (Figure 3.0). Install the end fascia beam furthest from the downpipe first. Lift the back channel end of the beam up into the wall or suspension bracket while supporting the other end on an adjustable construction prop. Adjust the construction props to allow for the required deck fall of minimum two degrees for Cooldek Classic and three degrees for Cooldek CGI. Fasten the end fascia beam to the bracket using two 12x20 hex head screws either side in the holes provided.

## Bracket and Filler Connections

Measure the front fascia beam. Mark where the end fascia beams, intermediate beams (if required) and columns meet. Clip the post

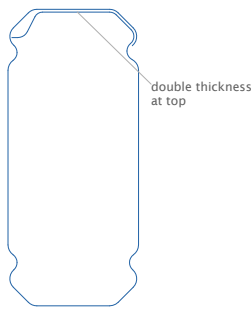

Figure 3.0

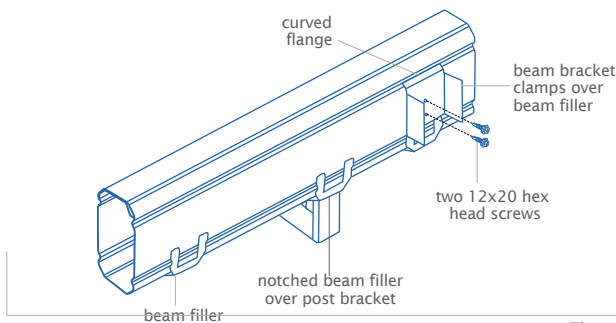

Figure 3.2

## In-Line Beam Connection

To butt join beams together, an in-line beam connector is used. The connector is placed so the join is in-line with the edge of a column. On the ground, slide the connector into the end of the beam. Fix using four 12x20 hex head screws either side. Push the exposed half of the in-line connector into the other beam until both beams meet flush and fasten as previously described (Figure 3.4). The post bracket at the in-line connection can now be fixed in place. Fasten using two 10x25 countersunk screws into the flute of the beam on each side.

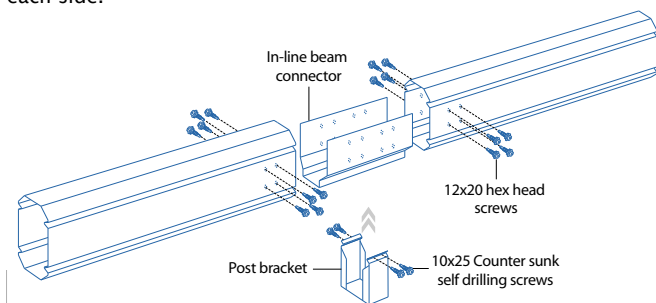

Figure 3.4

brackets onto the bottom of the front fascia beam where the columns will sit. Fasten through the holes in the post bracket with two 10x25 countersunk screws each side into the flute of the beam (Figure 3.1). Place the beam brackets on the inside face of the front fascia beam, aligning their curved flange with the top groove of the beam so that they clamp the beam fillers (notched beam filler if over a post bracket) in place, fasten using two 12x20 hex head screws (Figure 3.2).

## Beam to Beam Connection

Lift the front fascia beam and slide the beam bracket into the end of the end fascia beam. Support the front fascia beam on construction props allowing for a fall toward the downpipe. Fasten the end fascia beam either side with two 12x20 self drilling screws (Figure 3.3).

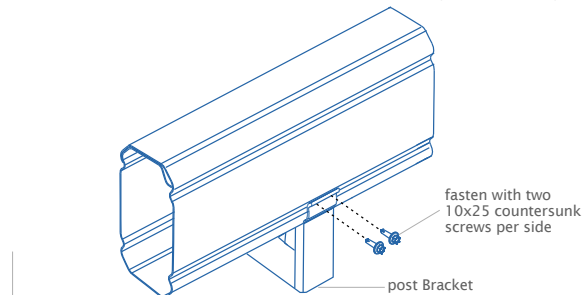

Figure 3.1

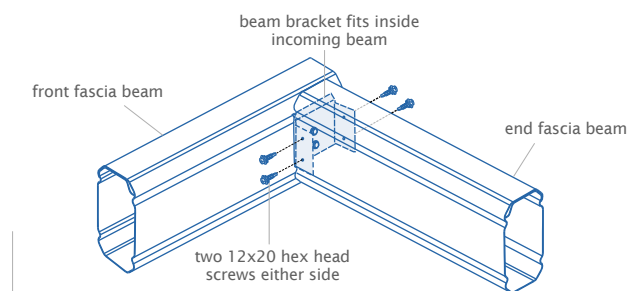

Figure 3.3

## Full Moment Beam Connection Detail

If the beams must be joined at a location other than over a post, a full moment beam connector is required (Figure 3.5). Slide the connector halfway inside the beam while it is still on the ground. Fix the connector in place using six 12x20 hex head screws; three either side of the beam. Push the exposed half of the full moment connector into the other front fascia beam until both beams meet flush and fasten using six 12x20 hex head screws; three either side of the beam.

Full Moment Beam Connector (mid span joiner)

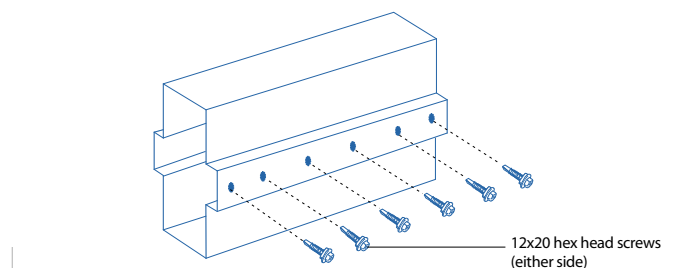

Figure 3.5

## Intermediate Beams and Purlins

If intermediate beams and/or purlins are required, they may be fitted at this stage or following installation of the columns. Work progressively from the first end of the unit. Locate the beam brackets and wall or suspension brackets in the correct positions and fasten as previously described. Lift the first intermediate beam into place and support on adjustable construction props, if purlins are required (i.e., type 4A Outback unit) do not secure the intermediate beam until the first purlin is lifted into position (Figure

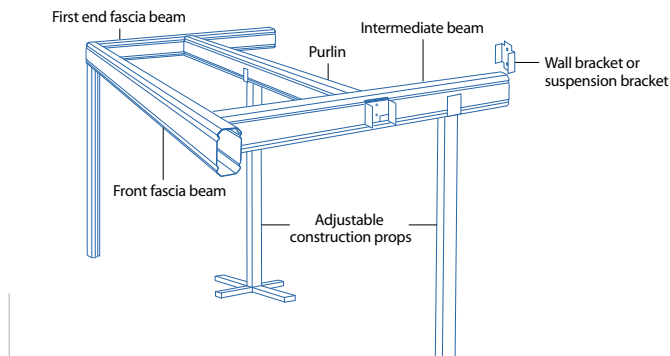

Figure 3.6

3.6). Secure all connections using two 12x20 hex head screws either side of each bracket. Continue this process along the Outback unit until the final end fascia beam is fixed in place.

## Framework Check

Check that the basic framework is square by ensuring the diagonal measurements are the same. Recheck the falls are correct for the roof and gutter (Figure 3.7).

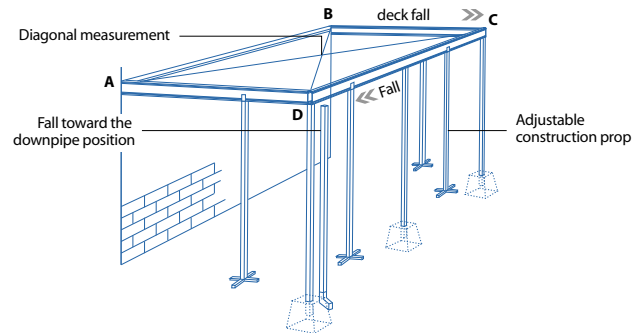

Figure 3.7

# COLUMNS AND FOOTINGS

## Columns and Footings

If fixing the columns into the ground, dig the holes to the specified size and place a brick in the bottom of the hole (Figure 4.0). At each post location, measure from the underside of the beam to the top of the brick and cut the columns to length. Check to ensure all columns are plumb.

If fixing posts to an existing concrete slab two options of footing plate are available please familiarise yourself with the footing type being used before reading on.

## Attached Verandah External Footing Plate

If an external footing bracket is being used (Figure 4.1) establish the column lengths by measuring the distance from the underside of the fascia beam to the concrete slab and deduct 20mm to allow for the depth of the footing bracket and cut the columns to length. Assemble the footing bracket by sliding the legs of the footing upstand through the slots in the plate (Figure 4.1). The upstand bracing must be located between the legs of the upstand. Slide the assembled footing bracket and bracing into the bottom of the column, and fasten with two 12x20 hex head screws either side ensuring the top screws are located at least 15mm from the top of the upstand with screws being a minimum 30mm apart.

## Attached Verandah Internal Footing Plate

If an internal footing bracket is being used (figure 4.2) establish the column lengths by measuring the distance from the underside of the fascia beam to the concrete. Place the 5mm washer plate inside the footing upstand and fix to the concrete with one M12x75 masonry anchors (minimum 75mm concrete edge distance). Measure the distance of the holes on the side of the footing upstands from the ground and mark this same position on the column. Drill a 13mm hole through this position on the column. Slide the column over the internal footing upstand and bolt through the column and the upstand with an M12 bolt. (Figure 4.2)

## Attach Column to Post Bracket

Slide the top of the column over the post bracket and align the column and footing bracket if applicable. It may be necessary to lift the fascia beam to slide the column over the post bracket. The un-fluted faces of the column should be aligned with each face of the post to beam bracket. Fasten with two 12x20 hex head screws either side (Figure 4.3). Post caps are used to cover the screw heads, press firmly into position, silicone can be used to provide a better fixing.

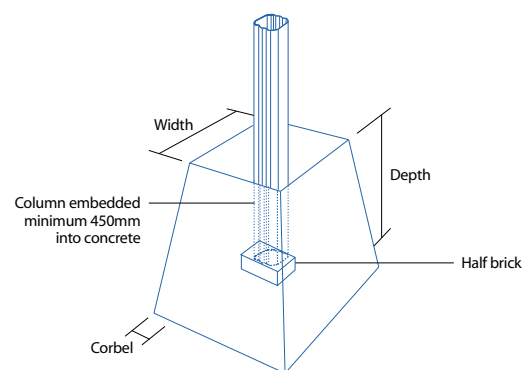

Figure 4.0

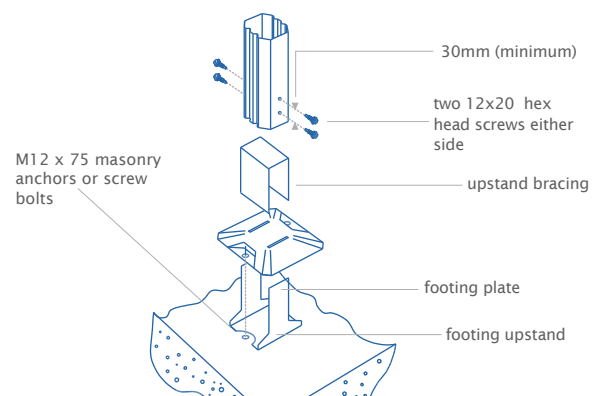

Figure 4.1

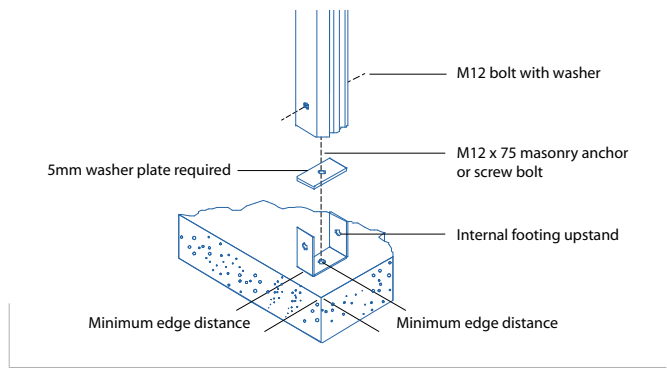

Figure 4.2

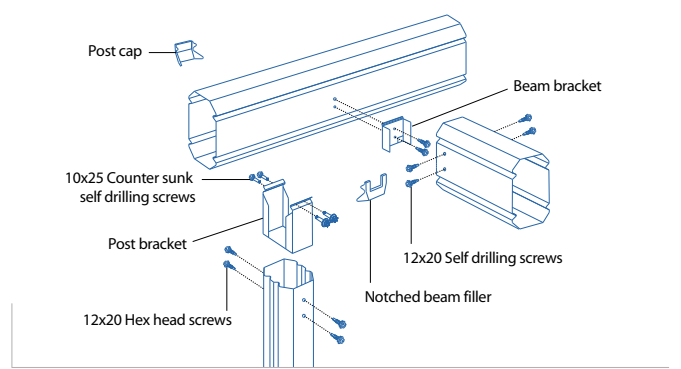

Figure 4.3

## CAPPING

To prevent moisture from entering the beams and for aesthetics, any beams with exposed ends require end caps to be fitted. Align the end cap and push into the exposed beam end (Figure 5.0).

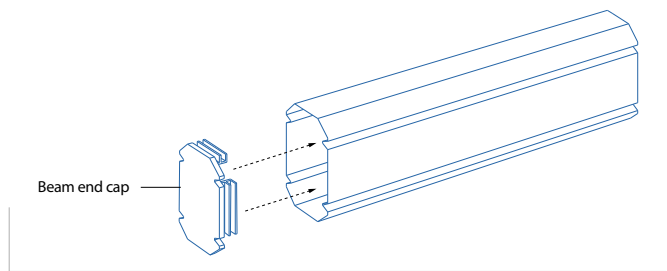

Figure 5.0

If Outback columns are used, the postcaps can be fitted over the post-beam connection. Apply a small amount of silicone to back of postcap, align the two lugs with the two exposed holes of the post bracket and push firmly (Figure 5.1).

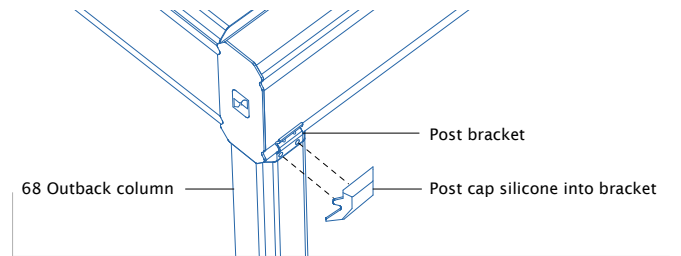

Figure 5.1

## ROOF SHEETS

There are two types of profiles in the Cooldek range; Cooldek Classic and Cooldek CGI, refer figure 6. The same procedure is used when fixing either option to the frame. Ensure that Classic is laid with a minimum fall of two degrees and CGI is laid with a minimum fall of three degrees.

If using Classic Cooldek pans must be turned up and down before the sheets are laid. The sheet should be turned down at the lower end of the roof at 30° to the horizontal. The top sheet is normally supplied 60mm longer than the insulating core and under sheet to allow for the front gutter to be attached. The sheet should be turned up at the higher end of the roof at 30° to the horizontal, see figures 6.1 and 6.2. If using CGI Cooldek, the sheets need only be turned up at the higher end using an adjustable spanner.

Mark the back channel and front fascia beam every 1000mm to check that the insulated roof panels are laid square.

**Note:** The minimum Cooldek sheet length is 2.0m. If your design requires sheets smaller than 2.0m they will be supplied at 2.0m and require cutting on site.

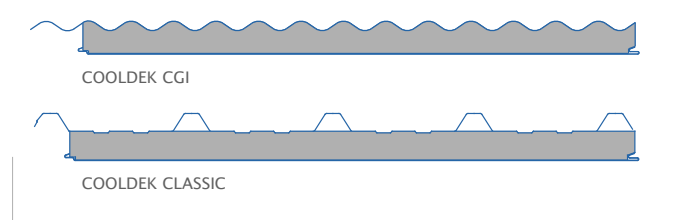

Figure 6.0

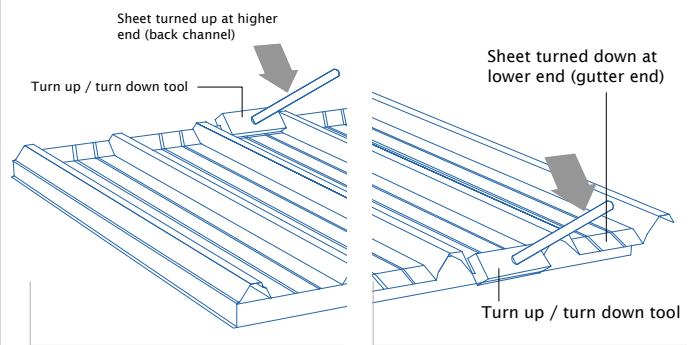

Figure 6.2

Figure 6.1

## FIXING THE PANELS

### Back Channel Fixing

Lift the first sheet into place and slide firmly into the BIP foam in the back channel to guarantee the correct weather proofing, (Figure 7.0). Check the sheet is square against the back channel and side fascia beam. Lay the next sheet of decking over the previous sheet's side lap and ensure that the slip joint of the two sheets has engaged, see Figure 7.3 and 7.4 (or Figure 7.7 if using CGI). Once all the sheets are

fitted secure the sheeting into the back channel with 4.8mm sealed rivets at maximum 200mm centres to the underside of the sheeting and 12 x 20 hex head screws with neoprene washer from the top into each crest for Classic profile and every third crest for CGI, refer Figure 7.0. If the sheets are being laid into the back channel with the crests running parallel to the back channel, rivet the sheets to the underside of the back channel as previously described, see Figure 7.1.

If using Classic profile and the sheets have been cut so there is no crest, you will need to turn up the pan 90°, before the sheet is slid into the back channel. Rivet the back channel to the panels from underneath as previously described. (See Figure 7.2)

## Beam Fixing

For Classic profile fix through each crest and for CGI profile fix through every second crest. If using 50mm Classic panels use 14x125mm hex head self drilling screws (14x150mm for 75mm Classic panels, 14 x 175mm for 100mm Classic panels, 14x110mm

for 50mm CGI panels, 14x125mm for 75mm CGI panels and 14x150mm for 100mm CGI panels). Pre-drill the crests of the ribs of the sheets to provide clean holes for the seating of neoprene washers. Use cyclone caps and neoprene washers in all crest fixings, see figure 7.5 or 7.6. Do not over tighten screws. Fix side laps with 12 x 20 hex head screw with neoprene washers at approximately 1000mm centres (see figure 7.4 or 7.7).

When sheeting runs parallel to beams (eg, side beams) fix panels with 14 gauge screws with neoprene washers at 500mm centres. Silicone to waterproof all rivets and pan fixed screws.

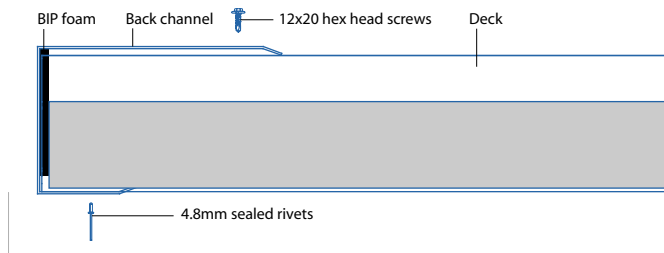

Figure 7.0

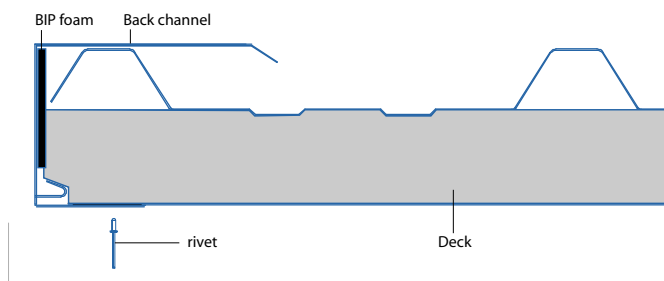

Figure 7.1

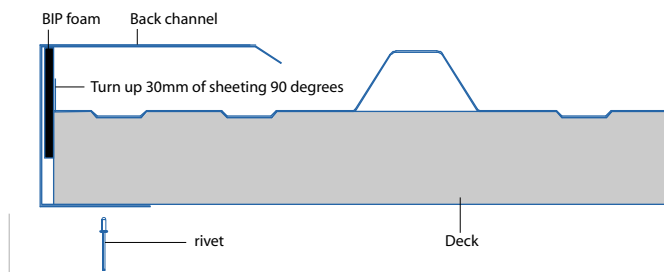

Figure 7.2

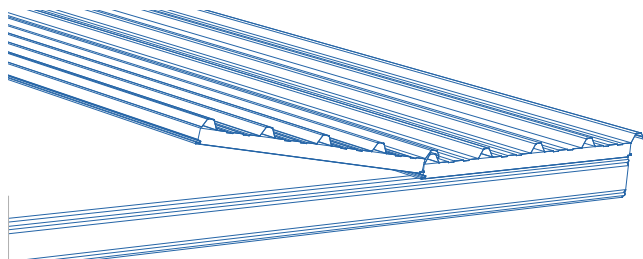

Figure 7.3

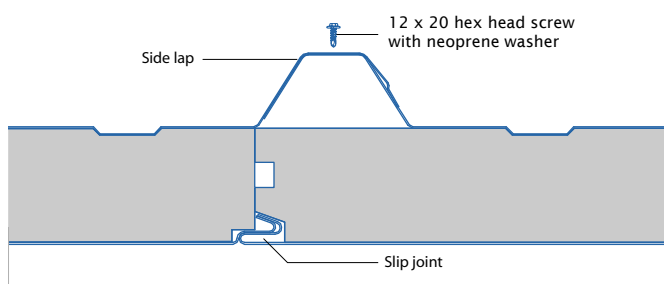

Figure 7.4

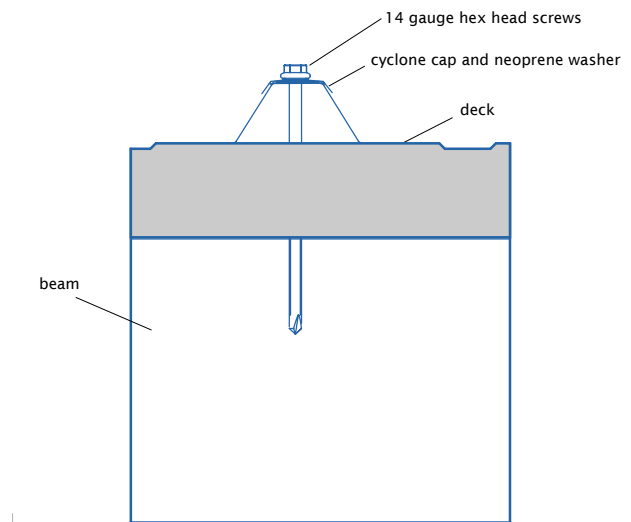

Figure 7.5

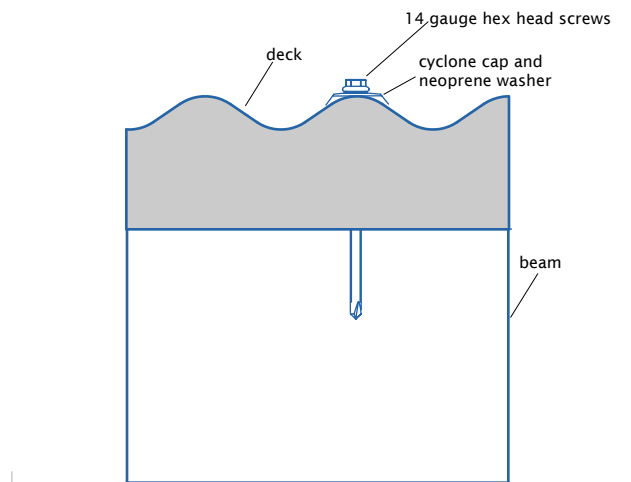

Figure 7.6

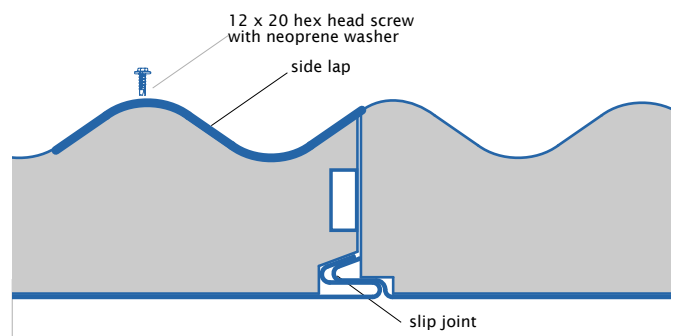

Figure 7.7

# GUTTER ASSEMBLY

## C-Square Gutter

To establish inside gutter length 'A' (figure 8.0), measure from the back of the back channel to the outside edge of the foam. To establish gutter length 'B' (figure 8.0) for the front gutter, measure the length of the front fascia beam. Attach the stop end to the side gutters with four rivets per stop end, remove any swarf and waterproof with silicone. Cut a 45 degree mitre on the front gutter at both ends. Cut a mitre out of the side gutter where it meets the front gutter and cut three tabs out of the side gutter which can be used to join the two gutters together. Pop rivet through the tabs to join the gutters together. Silicone all pop rivets and all around the gutter join to provide a waterproof seal. Refer figure 8.0.

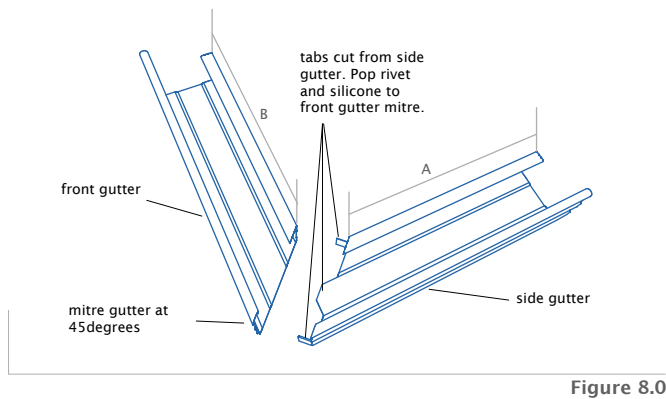

Figure 8.0

## Gutter Outlet

Position downpipe in line with column/s. Cut a hole in the base of the gutter near the back edge. Insert the gutter outlet pop from the inside of the gutter and rivet in place using 3mm rivets (figure 8.2), remove any swarf and waterproof with silicone. Note the different profile if Outback gutter is being used.

## Outback Gutter

To establish inside gutter length 'A' (figure 8.1), measure from the back of the back channel to the outside edge of the foam and subtract 5mm for the mitre bracket. To establish gutter length 'B' (figure 8.1) for the front gutter, measure the length of the front fascia beam and subtract 5mm for each mitre bracket. Attach the stop end to the side gutters with four rivets per stop end, remove any swarf and waterproof with silicone. On the gutter ends that will form a corner, cut a 45 degree mitre. Fit the mitre brackets using 3mm sealed rivets to fasten the mitre to the gutter then waterproof with silicone. Refer figure 8.1.

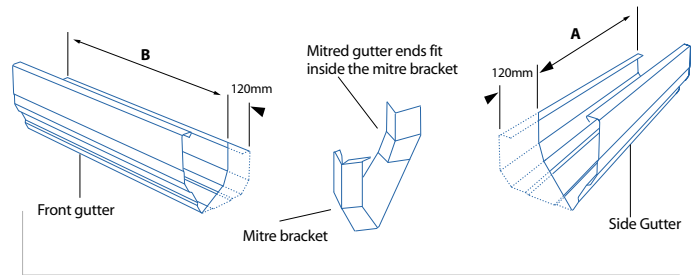

Figure 8.1

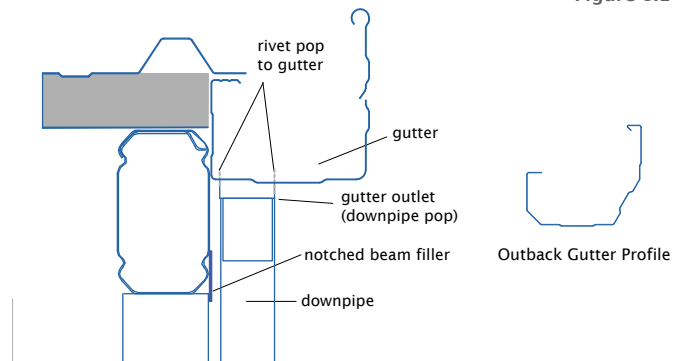

Figure 8.2

# SIDE GUTTER (WITH BEAM)

A 'cutback flashing' will be used to attach the gutter to the panels. Cutback the foam and bottom sheet so it is flush with the beam. Ensure that there is 30mm of top sheet overhanging the beam, which will be used to help attach the cutback flashing and the gutter. If using Classic Cooldek and if there is no crest present cut back the foam and bottom by 60mm and turn the top sheet up 90°, see Figure 9.1.

Slide the cutback flashing between the beam and the panels. Fix the cutback flashing in place by using the 14 gauge hex head screws through the panel and into the beam at 500mm centres (as

previously described). Lift the side gutter so that the stop end slides up behind the back channel and rivet the gutter to the top sheet and cutback flashing at 1000mm centres. Attach gutter straps to the top sheet or crest at 1000mm centres. See Figure 9.0, 9.1, 9.2, 9.3 or 9.4 depending on your case.

When fixing gutters always ensure that the front face of the gutter remains vertical and even. All screws to have neoprene washers. Silicone to waterproof all rivets and pan fixed screws.

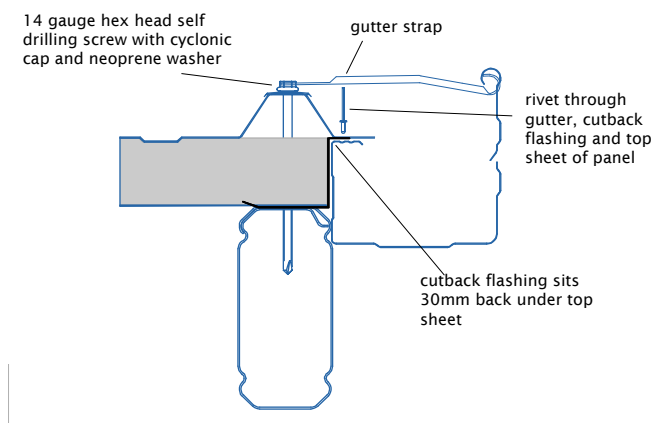

Figure 9.0

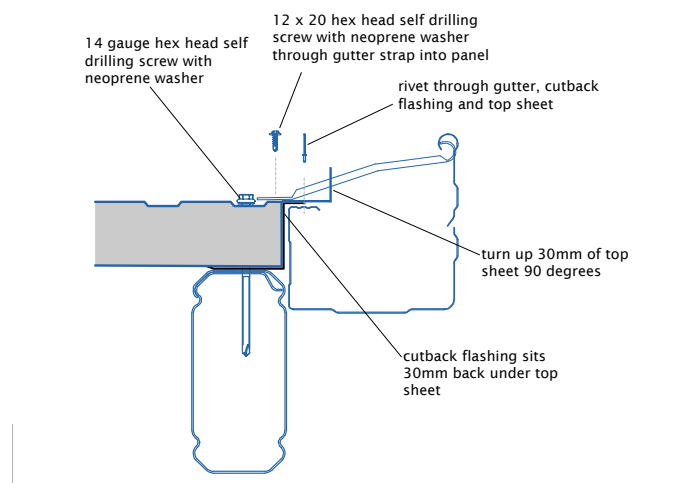
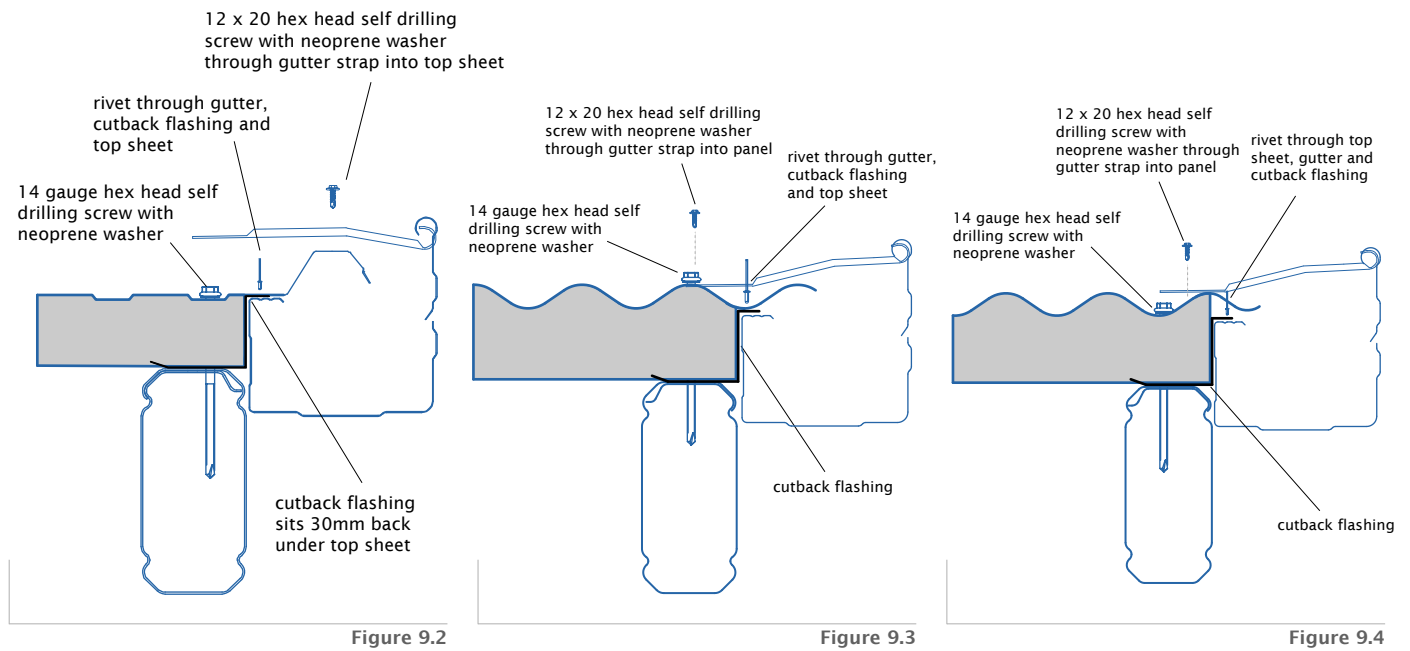

Figure 9.1



## SIDE GUTTER (WITHOUT BEAM)

A 'cutback flashing' will be used to attach the gutter to the panels. Cutback the foam and bottom sheet so 30mm of top sheet is now overhanging past the foam. This will be used to help attach the cutback flashing and the gutter.

If using Classic Cooldek and if there is no crest present cut back the foam and bottom by 60mm and turn the top sheet up 90°, see Figure 10.2.

Position the cutback flashing as shown in the following five figures. Rivet the cutback flashing to the panel at 500mm centres. Lift the side gutter so that the stop end slides up behind the back channel and rivet the gutter to the top sheet and cutback flashing at 1000mm centres. Attach gutter straps to the top sheet or crest at 1000mm centres. See figure 10.0, 10.1, 10.2, 10.3 or 10.4 depending on your case.

When fixing gutters always ensure that the front face of the gutter remains vertical and even. All screws to have neoprene washers. Silicone to waterproof all rivets and pan fixed screws.

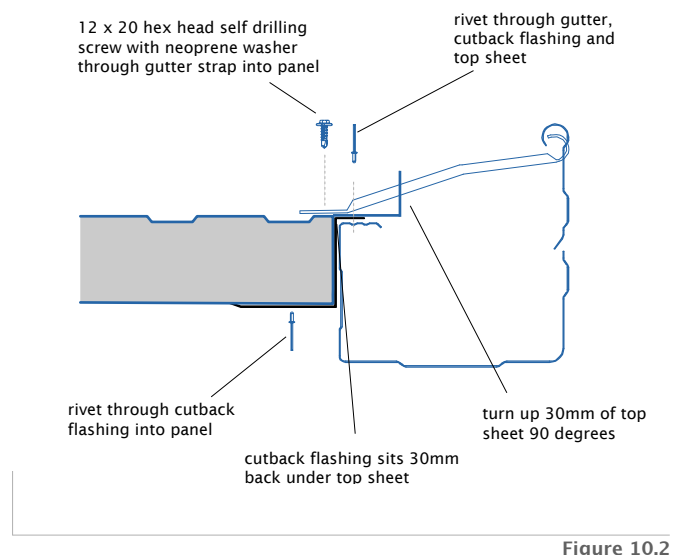
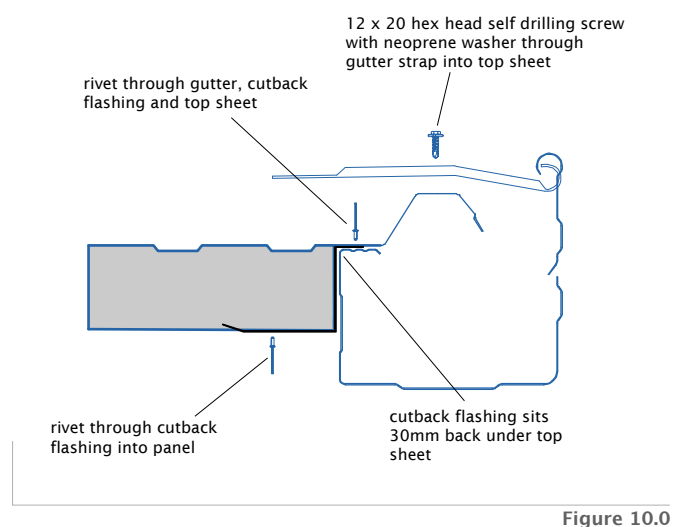
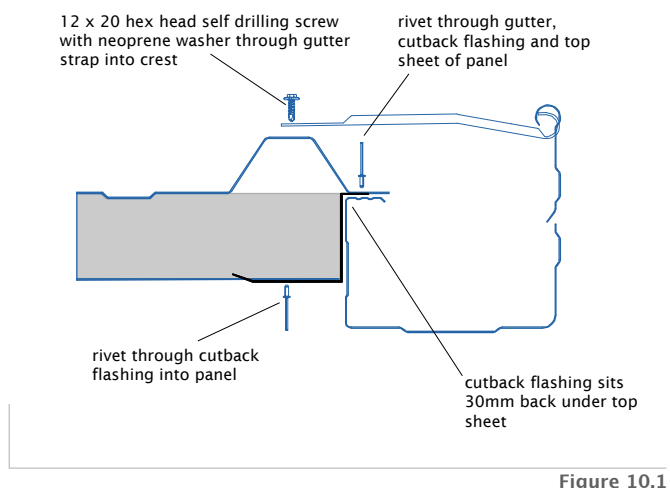

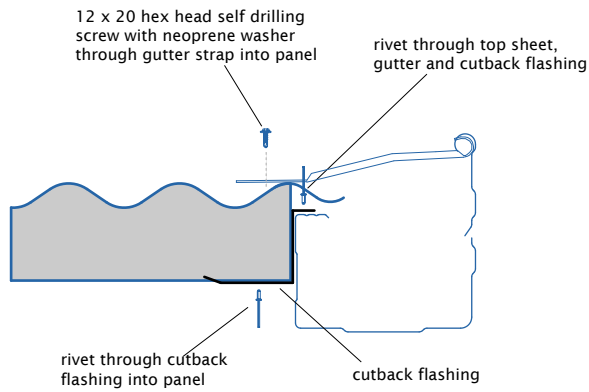

Figure 10.3

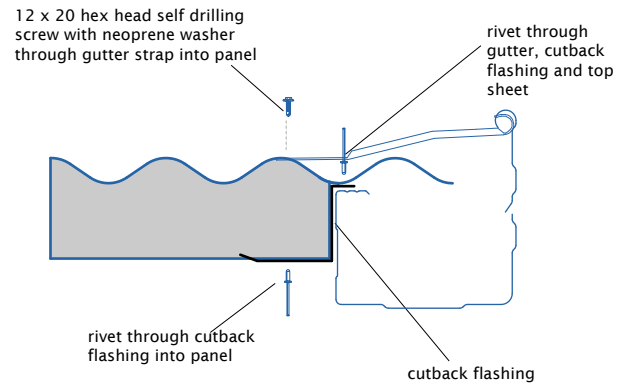

Figure 10.4

## SIDE CAPPING (WITH BEAM)

If side gutters are not required then side cap flashings will be used on the side of the unit. The flashing will fit inside the back channel, where they meet and cover the side of the unit.

Slide the side cap flashing between the beam and the panels. Fix the flashing in place by using the 14 gauge hex head screws through the flashing, panel and into the beam at 500mm centres (as previously described). Rivet the flashing to the crests of the panel at 1000mm centres. (See Figures 11.0, 11.1, 11.2 and 11.3.)

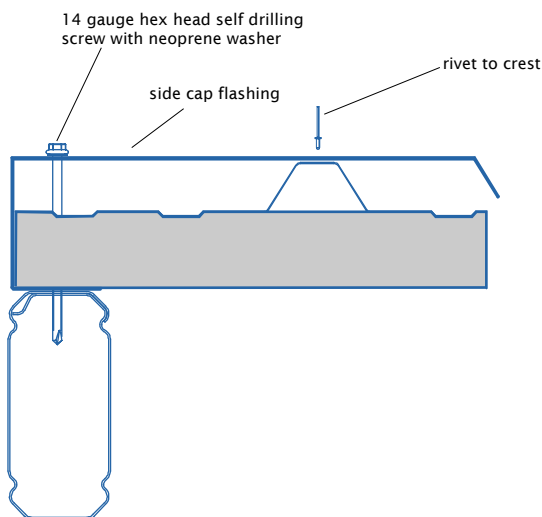

Figure 11.0

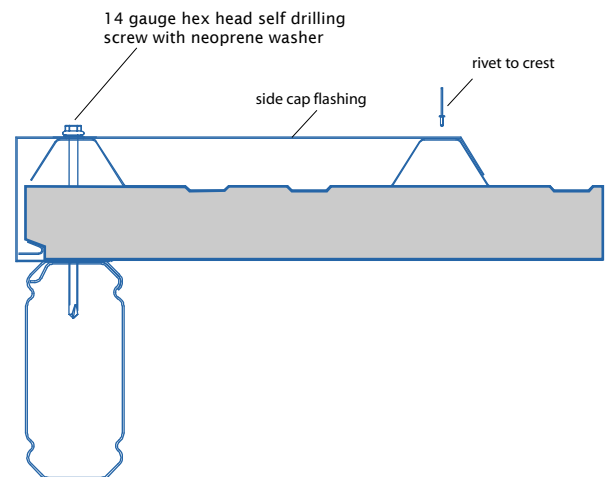

Figure 11.1

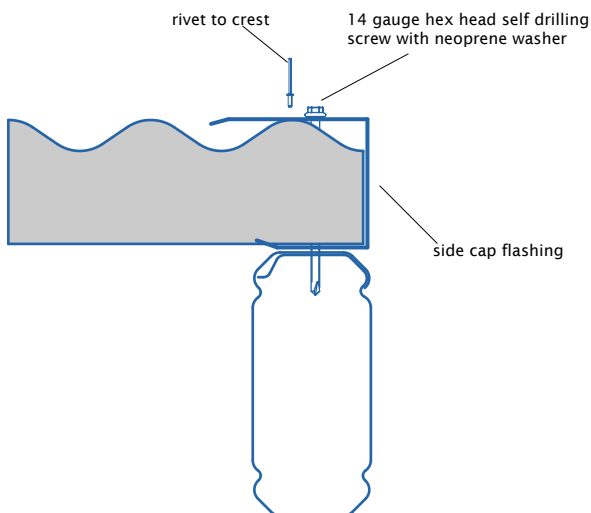

Figure 11.2

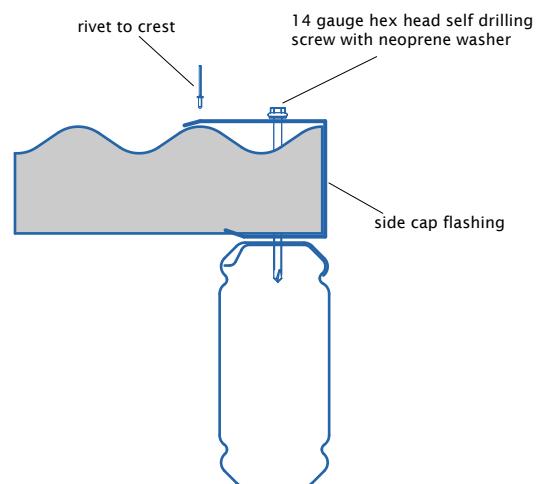

Figure 11.3

## SIDE CAPPING (WITHOUT BEAM)

If side gutters are not required and no side beams are present, then side cap flashings will be used on the side of the unit. The flashing will sit inside the back channel and cover the side of the unit.

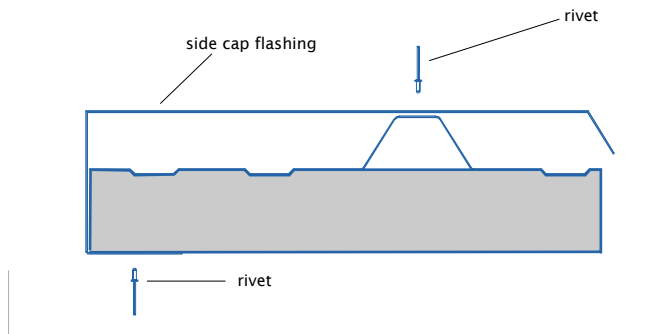

Figure 12.0

Slide the side cap flashing in over the panels. Rivet the flashing to the crests and underside of the panel at 1000mm centres. Examples can be seen in (Figures 12.0, 12.1, 12.2 and 12.3).

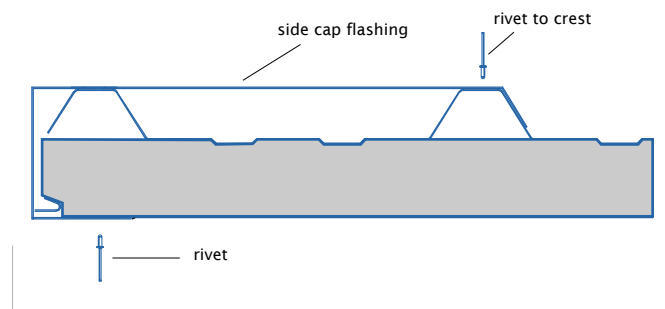

Figure 12.1

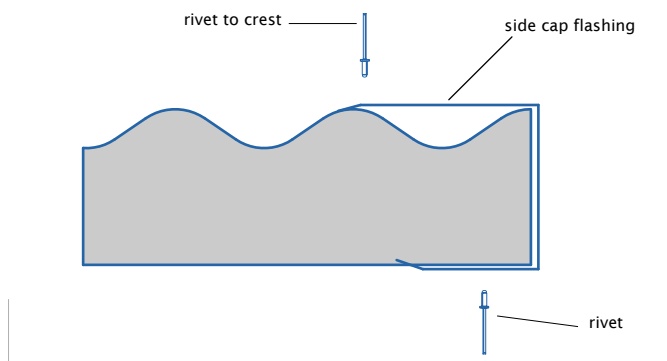

Figure 12.2

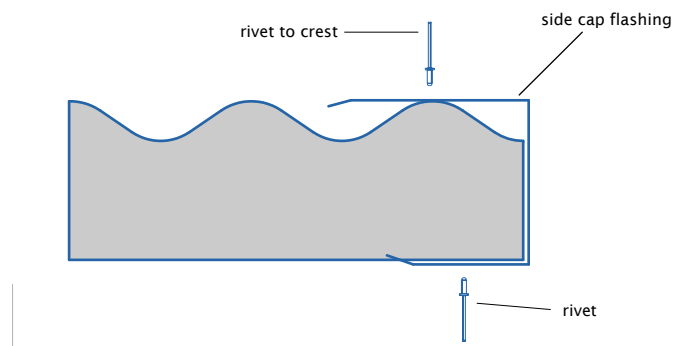

Figure 12.3

## FRONT GUTTER

The front gutter will be fixed to the attached 60mm Cutback Flashing already on the panels. Lift the front gutter into place and rivet through the top sheet and cutback flashing at 1000mm centres. Rivet and silicone the gutter corners on the mitred edge. Attach gutter straps to top sheet ribs at 1000mm centres (Figure 13.0).

### Final Side Gutter

Attach the final cutback flashing to the final side of the unit as previously described. Lift the final side gutter so that the stop end slides up behind the back channel. Fix gutter in position as previously described.

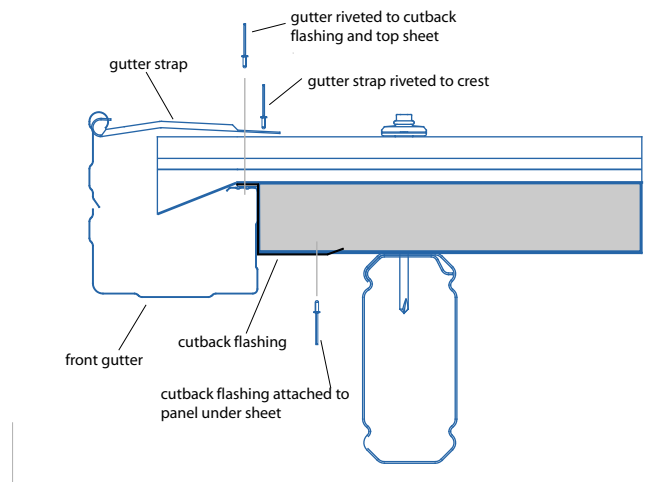

Figure 13.0

## LOWER END CLOSURE

The panels should be closed in order to protect against moisture and vermin. Use foam vermin proofing supplied see (Figure 14.0). If CGI roofing sheets are being used then vermin proofing foam will not be required.

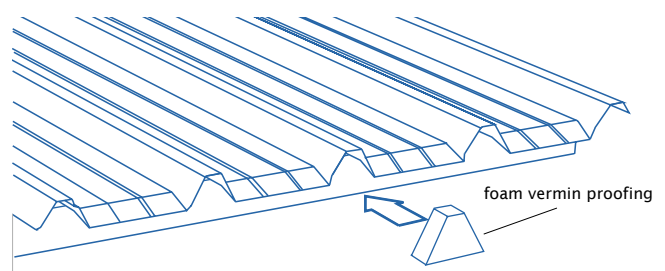

Figure 14.0

## FINAL FIXING

### CONTACT

1300 165 165

### Final Fixing into the Concrete Footing

Thoroughly check the posts with a spirit level. When plumb, fill the post hole with approximately 150mm of concrete and use a shovel or pole to agitate the concrete to remove any air pockets. Repeat this process until the hole is full, continually checking the posts as you go. The concrete must have a slight slope that runs away from the column to ensure any water does not pool around the base (Figure 15.0). Once the concrete is set remove any temporary bracing or props.

### Final Fixing onto Existing Concrete – External Footing

If the columns are to be fixed to an existing concrete slab with an external footing plate, each plate must be fixed to the concrete with two M12x75 masonry anchors or two M12x75 screwbolts (Figure 15.1). The minimum distances from an anchor hole to the concrete edge is 75mm for M12 anchors.

### Final Fixing onto Existing Concrete – Internal Footing

Ensure the M12 bolt is tightened. (See Figure 15.2).

### Important Note

Do not allow soil to remain in permanent contact with the columns, as corrosion will result in the base of the column. Refer to the “Selection, Use and Maintenance of Stratco Steel Products” brochure for complete details of the maintenance requirements.

### Downpipes

Before attaching the downpipes, rivet the downpipe bracket to the column and bend the flanges along the ‘break-line’ to accept the downpipe. Slide the downpipe over the downpipe outlet and rivet into position. Rivet the downpipe to the brackets. Weatherproof all the fasteners with silicone.

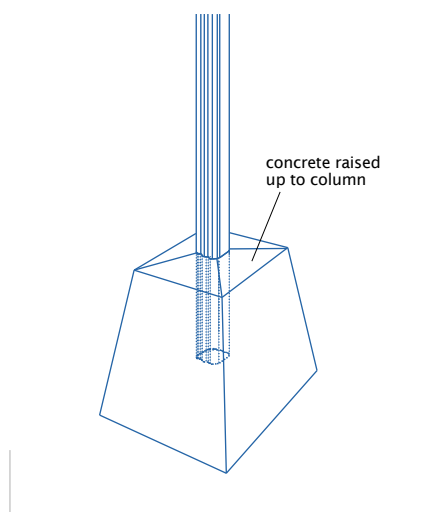

Figure 15.0

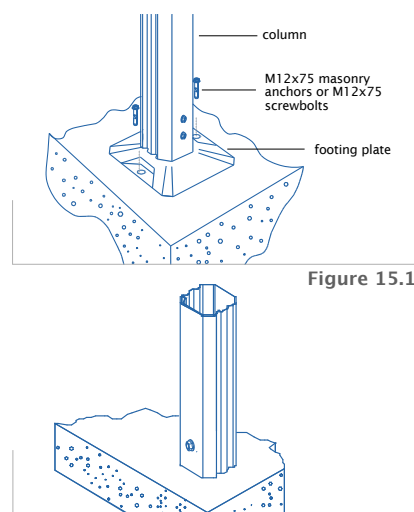

Figure 15.1

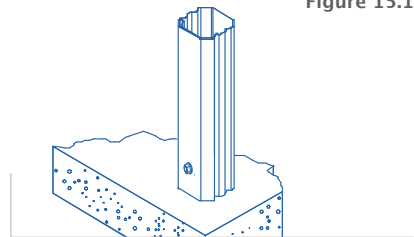

Figure 15.2

## MAINTENANCE

Regular maintenance is essential to maintain the good looks of all Stratco steel products and to ensure you receive the maximum life-span possible. Washing with clean water must be frequent enough to prevent the accumulation of dust, salts, and pollutants that may reduce the life of the product. Stratco steel products that are regularly washed by rain require no additional maintenance. No Stratco steel structure or materials are recommended for use over, or in close proximity, to swimming pools or spas. No material that retains water (such as dirt or paving sand) should be placed against the columns. Care must be taken when determining the location of Stratco steel products so that they are not placed in close contact with sources of pollution or environmental factors that could affect the life of the steel. Refer to the ‘Selection, Use and Maintenance’ brochure for more information.