

HANDI-MATE™ SHED

HANDI-MATE™ LOCKER INSTALLATION GUIDE

INSTALL GUIDE

BEFORE YOU START

PRIOR TO INSTALLATION

It is important that you contact your local government authority to determine if building approval is required.

To ensure that the installation and erection of your Stratco Handi-Mate™ Shed proceeds smoothly you should confirm that all the components and materials listed on the delivery documentation and in this installation guide have been supplied. Details for ordering individual components can be found in the “Component Index” section at the end of this document.

Carefully read this installation guide to familiarise yourself with all the steps involved and ensure that you have the correct tools and equipment for the job.

All Stratco Handi-Mate™ Sheds must be securely bolted to a permanent concrete base with sufficient masonry anchors securing all four corners of the Handi-Mate™ shed to prevent wind uplift.

SHED WINDOWS (OPTIONAL)

Stratco Shed Windows are available as an optional add-on, available in both Louvre and Sliding variations. Refer to the “Window Installation” section if installing a Stratco Window, or visit your local Stratco store for more information.

FLOORING PREPARATION

The installer is responsible for ensuring the slab or concrete pads are sufficient to support the shed and sustain wind loading.

Do not directly anchor your shed to pavers.







Option 1 - Before building the shed, pour a base that is larger than the area by at least 200mm in each direction. The base should be poured so the concrete outside the shed floor area slopes away from the shed to help prevent water from entering the shed.

Option 2 - Substantial concrete pads may be used at each anchor location as an alternative to a complete concrete floor. It is recommended pads are minimum Ø250mm x 400mm deep, embedded into a firm natural soil base.

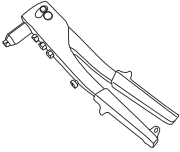
IMPORTANT NOTES:

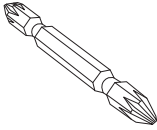
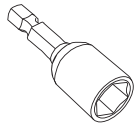
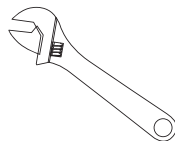
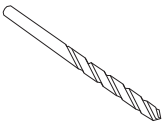
1. It is essential to clear and level the site prior to assembling your Stratco Handi-Mate™ Shed.
2. Note there are different types and colours of screws. Ensure that the right type and colour screw is being used at each location.
3. Stability and performance of the shed relies on the door being closed during high wind events.
4. Do not traverse the roof of the Handi-Mate™.
5. Use heavy gloves when handling steel sheeting and flashings and never attempt to install a shed in windy conditions.

TOOLS REQUIRED

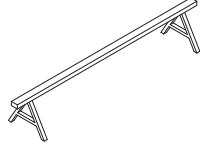
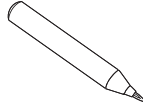
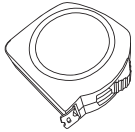



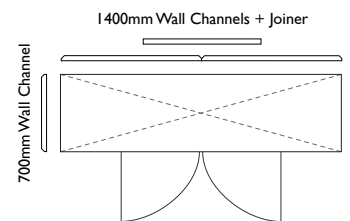
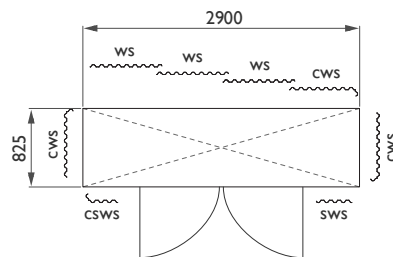
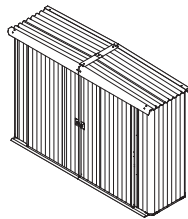

					
Rivet Gun	Power Drill	Phillips Head Driver	Hex Head Driver	Adjustable Spanner	3.5mm & 12mm Drill Bit 10mm Masonry Bit
					
Gloves	Safety Glasses	Step Ladder	2 x Trestle / Saw-horse	Permanent Marker	Tape Measure

COMPONENTS



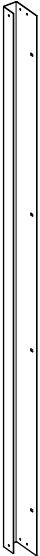







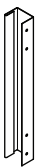
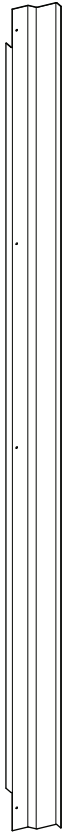
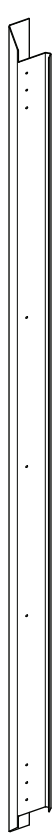





Handi-Mate™ Locker











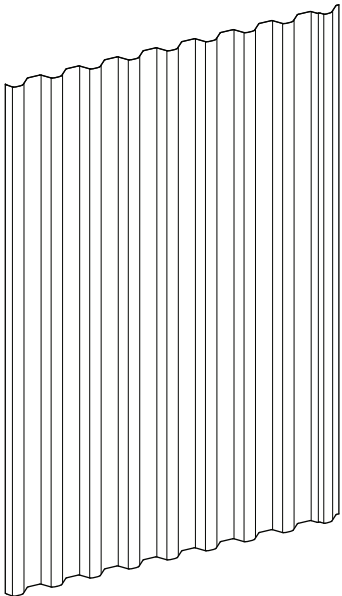



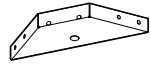
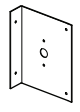

Corner Split Wall Sheet - CSWS
 Corner Wall Sheet - CWS
 Split Wall Sheet - SWS
 Wall Sheet - WS



						
L/H Barge Cap	R/H Barge Cap	Top Door Channel	Bottom Door Channel	Door Shroud	Vertical Door Channel	Door Jamb

COMPONENTS

									
									
Sliding Rail Joiner	Ramp Channel Joiner	Ridge Cap	Ridge Beam	Barge Support	Sliding Rail	Bottom Channel	Runner Rail	Wall Channel	Wall Channel Joiner

					
	Door Wheel	Door Nut	Door Stop	Corner Bracket	Handle Mount
					
	Pad Bolt	Hasp & Staple	Hold Down Lug	M8x47 Masonry Anchor	10x16 Wafer-Head Screw
					
10x22 Wafer-Head Screw	10x25 Self-Drilling Coloured Screw (with neo washer)	10x16 Self-Drilling Screw (with neo washer)	10x16 Self-Drilling Screw	Aluminium Rivet	
					
Roof Sheet	Coloured Rivet				

COMPONENTS

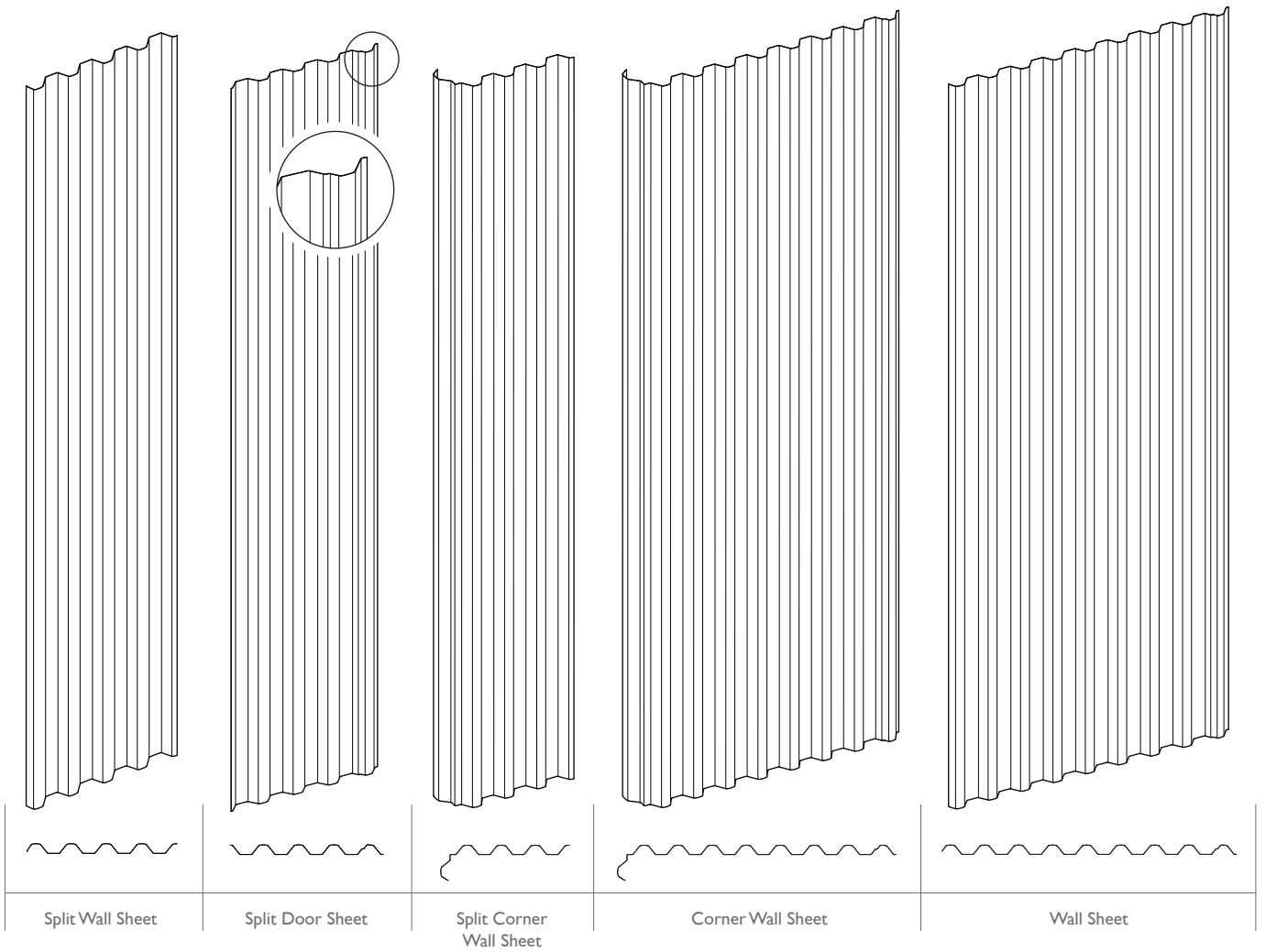

Figure I.0

SIDE WALL ASSEMBLY

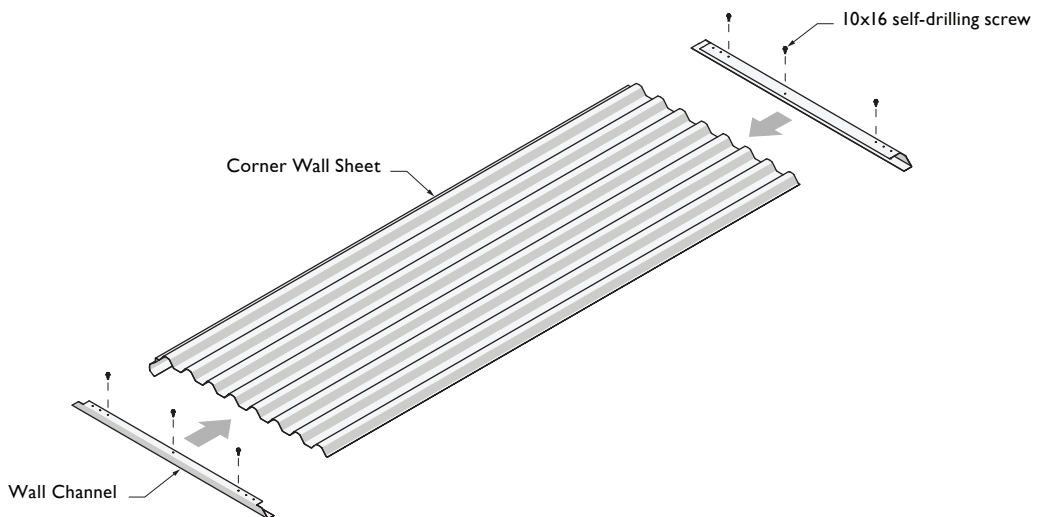

Figure I.1

When assembling the Wall and Door Sheets, lay the sheets down on trestles/blocks (Figure 1.2). This will make assembly easier and reduce the risk of damage to components.

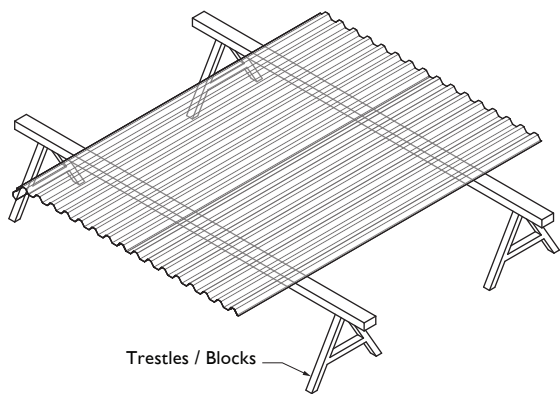

Figure 1.2

Fit the Wall Channels over the Wall Sheet. The end of the Wall Channels should fit up against the end of the Corner Wall Sheet (Figure 1.3).

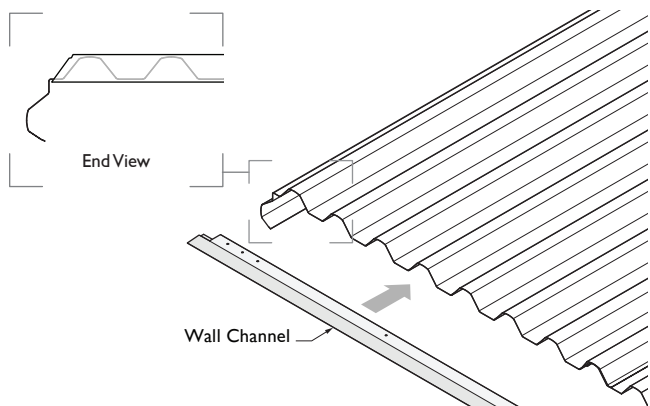

Figure 1.3

Ensure pre-made pilot holes in the Wall Channel line up in the centre of the Wall Sheet crests (Figure 1.4). Pulling the Wall Sheet into place may be required to achieve this.

Note: Ignore the final two holes at the ends of the wall channels.

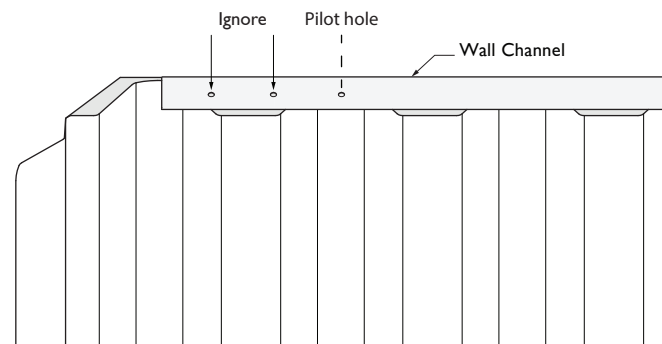

Figure 1.4

Fasten the top and bottom Wall Channels to the Wall Sheets using 10x16 self-drilling screws through each pilot hole, ignoring the two holes at each end (Figure 1.5).

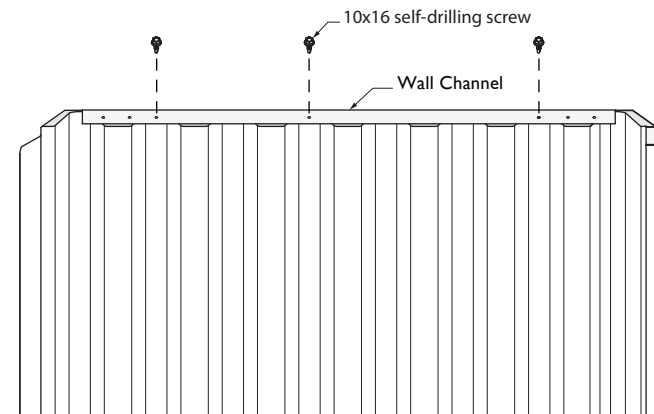

Figure 1.5

REAR WALL ASSEMBLY

Stratco Shed Windows are available as an optional add-on. Refer to the "Window Installation" section at the end of this document if installing a Stratco Window, or visit a Stratco store for more information.

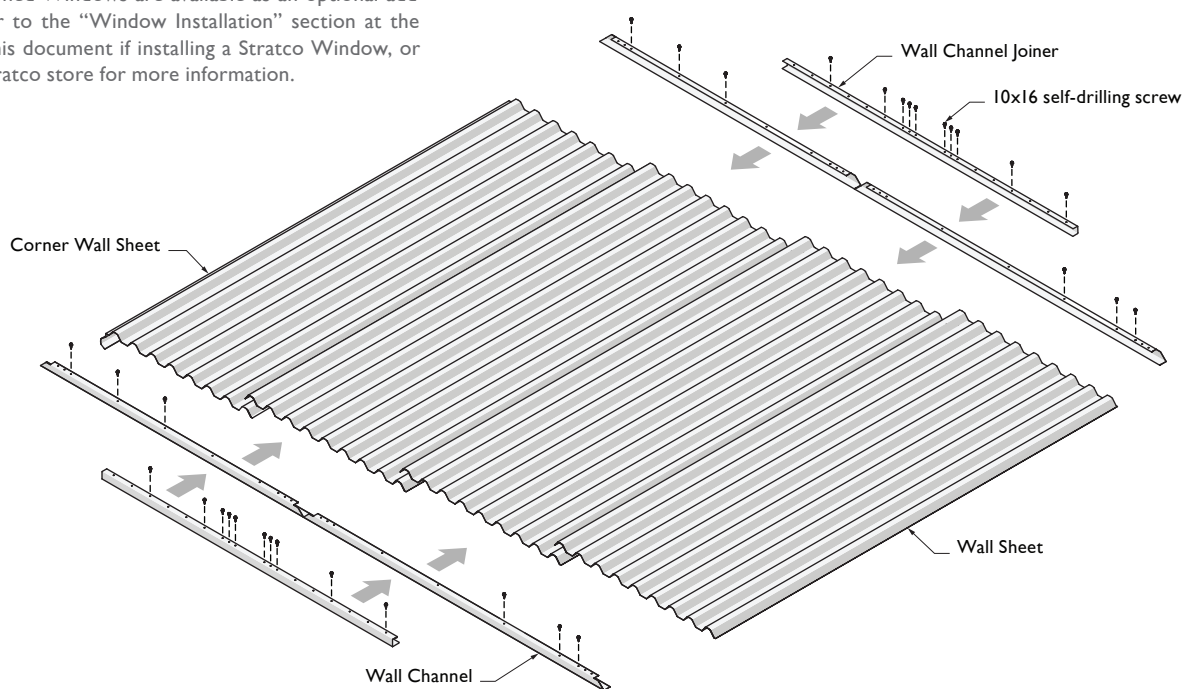

Figure 2.0

Slide both Wall Channels into the Wall channel Joiner. Ensure the four middle pre-punched holes of the Wall Channel Joiner and Wall Channels line up. Fasten 10x16 self-drilling screws through the four middle pilot holes of the Wall Channel Joiner and into the Wall Channel (Figure 2.1). Assemble a second set of Wall Channels and Joiner in the same manner.

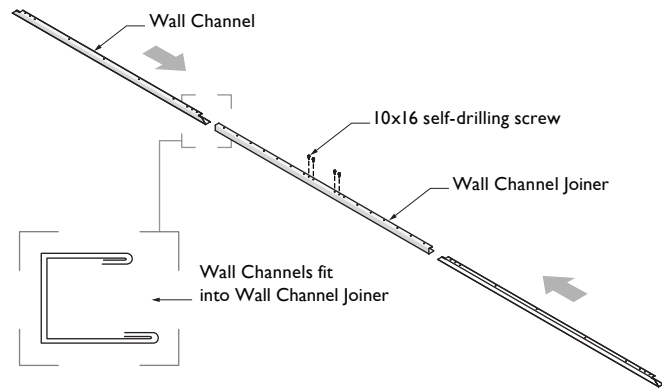

Figure 2.1

Place the Corner Wall Sheet onto the Trestles/ Blocks first. Lay the next Wall Sheet overlapping the Corner Wall Sheet (Figure 2.2). Subsequent Wall Sheets can be overlapped in the same manner. Refer to the "Components" section for specific wall sheet configurations.

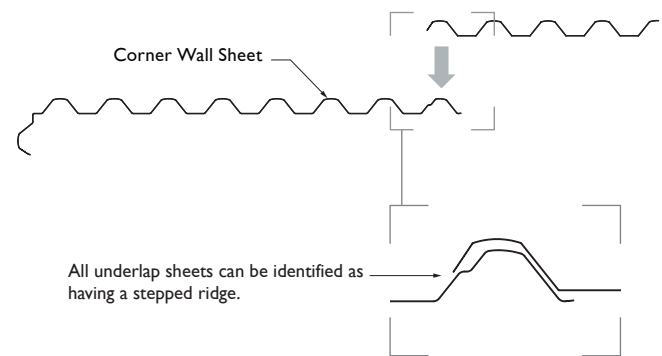

Figure 2.2

Once all Wall Sheets are lapped the Wall Channels can be fitted. Fit the Wall Channel over the lapped Wall Sheets. The end of the Wall Channel should fit up against the end of the Corner Wall Sheet (Figure 2.3).

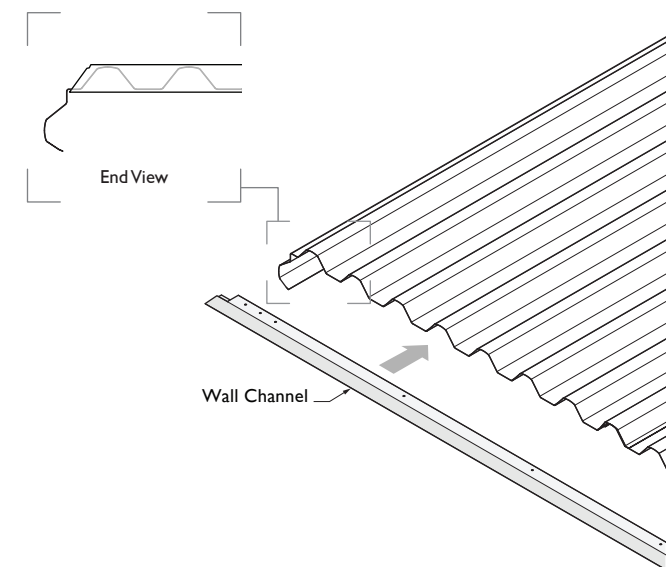

Figure 2.3

Ensure pre-made pilot holes in the Wall Channel line up in the centre of the Wall Sheet crests (Figure 2.4). Pulling the Wall Sheet into place may be required to achieve this.

Note: Ignore the final two holes at the ends of the wall channels.

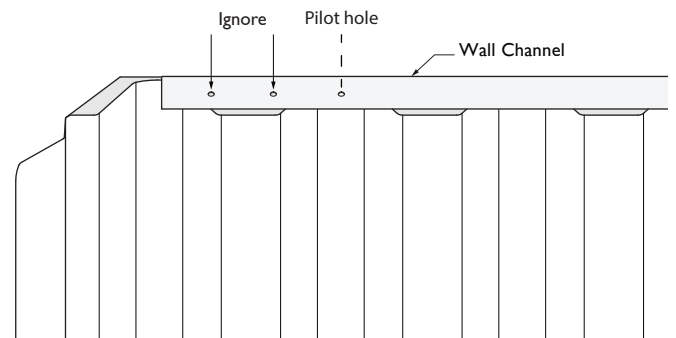

Figure 2.4

Starting at the third pilot hole from the end, Fasten 10x16 self-drilling screws through the top and bottom Wall Channels into every third Wall Sheet crest (Figure 2.5).

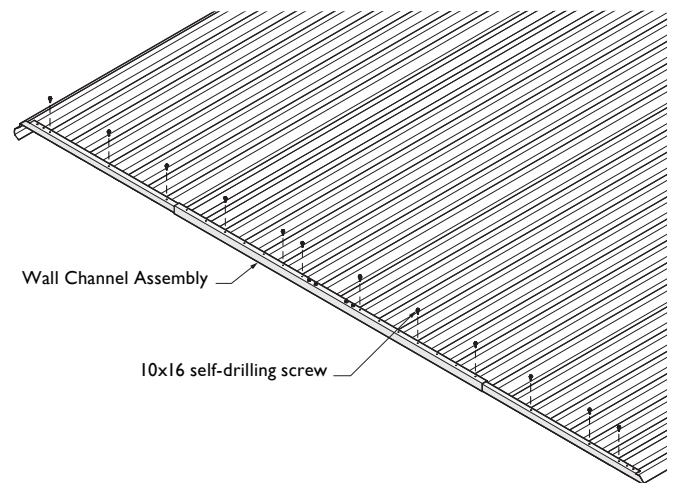

Figure 2.5

Join any overlapping sheets to one another using coloured rivets through the mid-span of lapping crests (Figure 2.6). Drill a hole with the Ø3.5mm drill bit into the centre of the lapping crests. Use a Rivet Gun to rivet the sheets together.

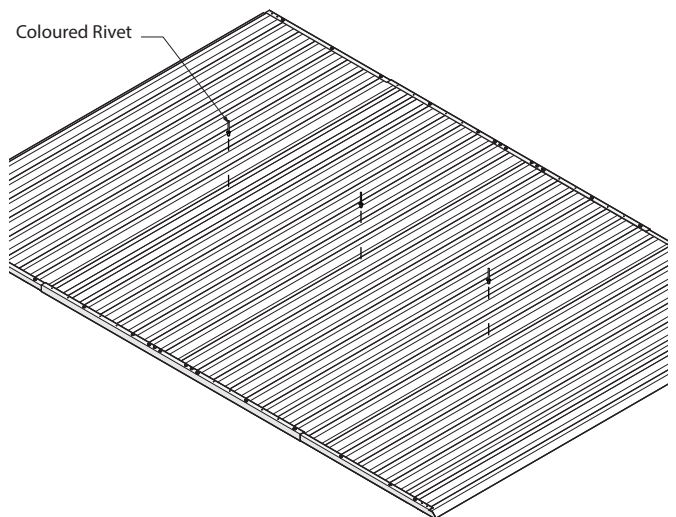

Figure 2.6

FRONT WALL ASSEMBLY

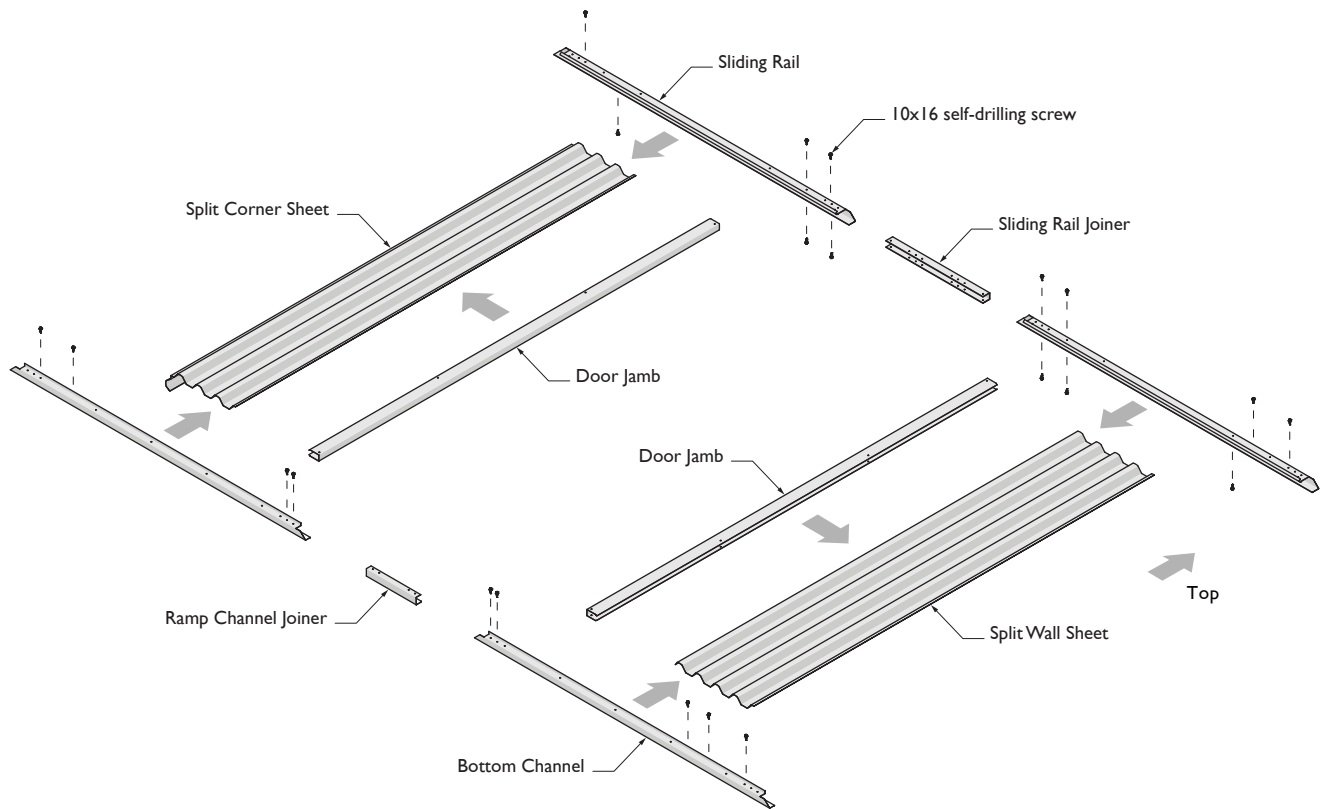

Figure 3.0

Slide both Bottom Channels into the Ramp Channel Joiner. Ensure the four middle pre-punched holes of the Ramp Channel Joiner and Bottom Channels line up. Fasten 10x16 self-drilling screws through the four middle pilot holes of the Ramp Channel Joiner and into the Bottom Channels (Figure 3.1).

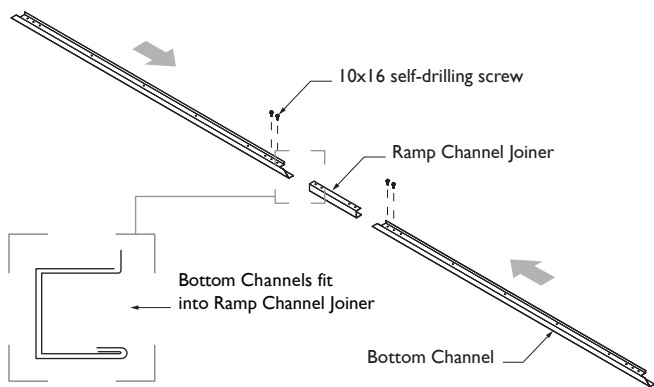

Figure 3.1

Slide both Sliding Rails over the Sliding Rail Joiner. Ensure the middle pre-punched holes of the Sliding Rail Joiner and Sliding Rail line up. Fasten eight 10x16 self-drilling screws through the pilot holes of the Sliding Rails and into the Sliding Rail Joiner (Figure 3.2).

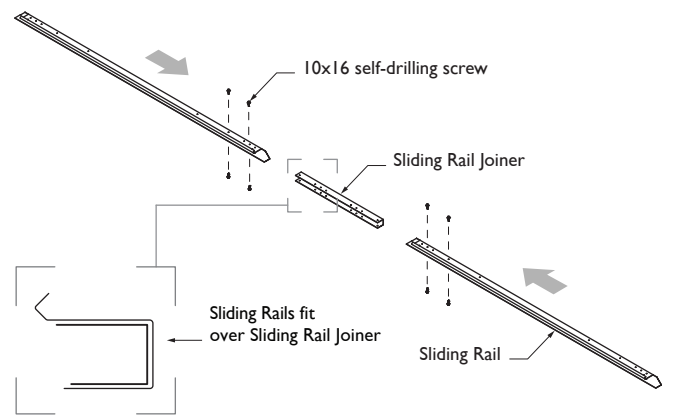

Figure 3.2

Fit the Bottom Channel and Sliding Rail over the Wall Sheets (Figure 3.3). The end of the Channels should fit up against the ends of the Corner Wall Sheet (Refer Figure 2.3).

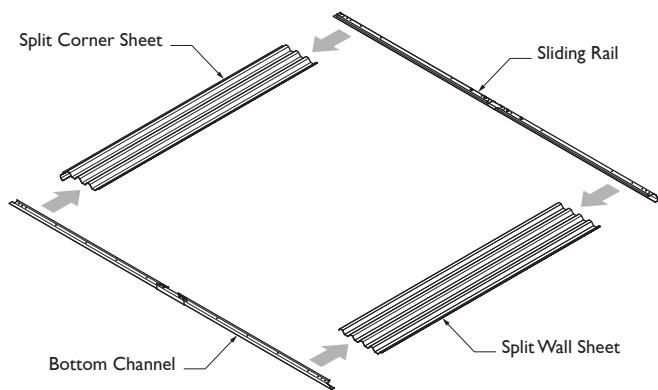

Figure 3.3

Fasten one 10x16 self-drilling screw through the third pilot hole of the Bottom Channel and into the corresponding Wall Sheet crest. Fasten another 10x16 self-drilling screw through the third pilot hole of the Sliding Rail and into the Wall Sheet (Figure 3.4).

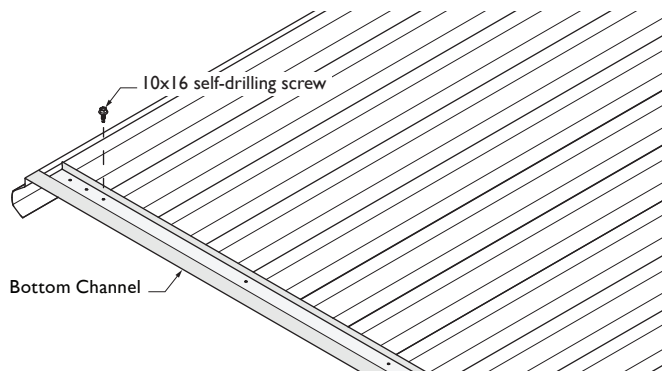

Figure 3.4

Fit the Door Jambs into the Bottom Channel and Sliding Rail. Position the Door Jambs over the Wall Sheets. Secure the Bottom Channel and Sliding Rail to the Split Wall Sheet with four 10x16 self-drilling screws (Figure 3.5).

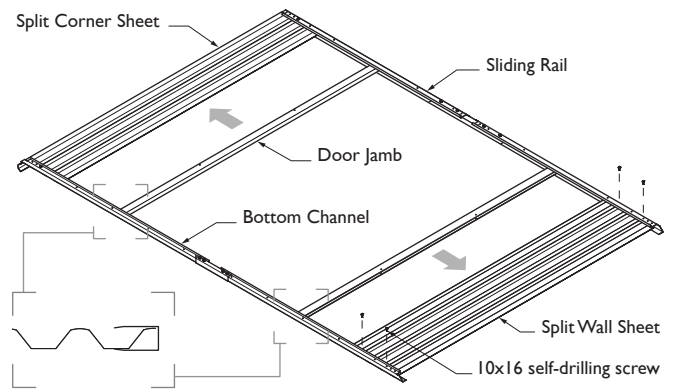

Figure 3.5

Set the correct spacing of the Door Jambs using the Door Shroud as a guide. Fasten the Door Jambs with four 10x16 self-drilling screws (Figure 3.6).

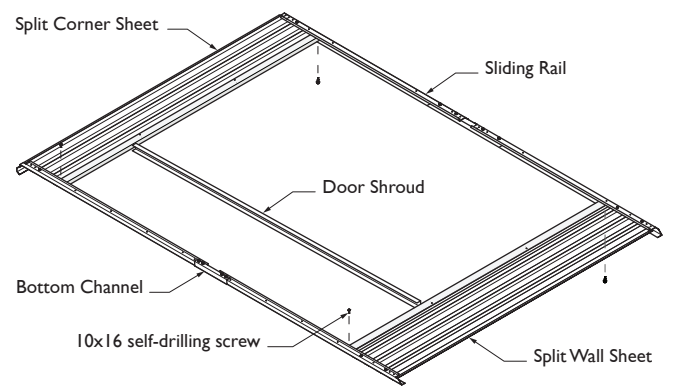

Figure 3.6

DOOR ASSEMBLIES

Both door assemblies are assembled in a similar manner, with the second door assembly being a mirror of the first.

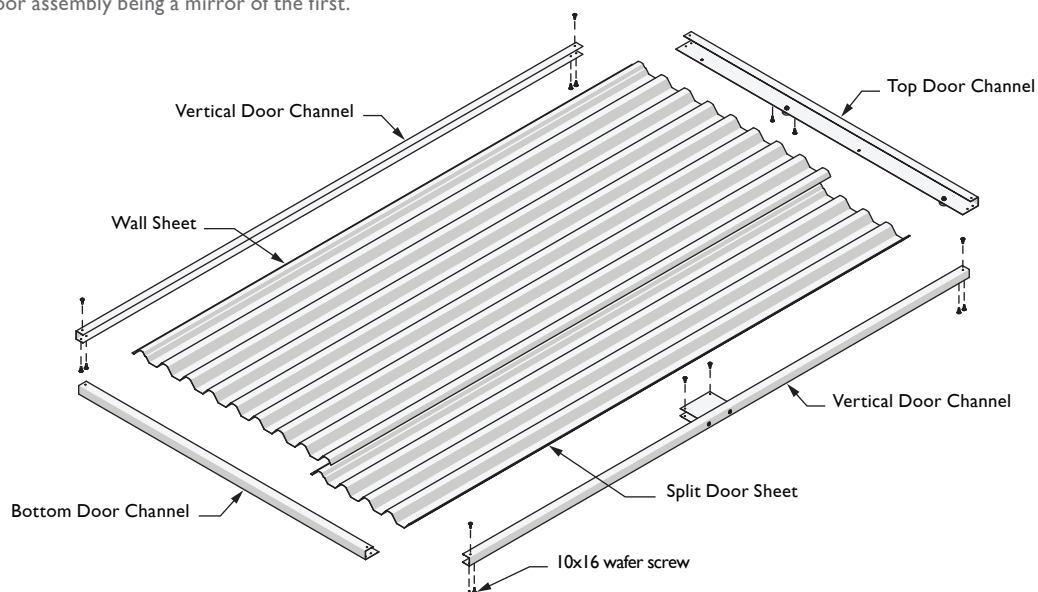

Figure 4.0

Fix the Door Wheels to the Top Door Channel using Door Nuts (Figure 4.1).

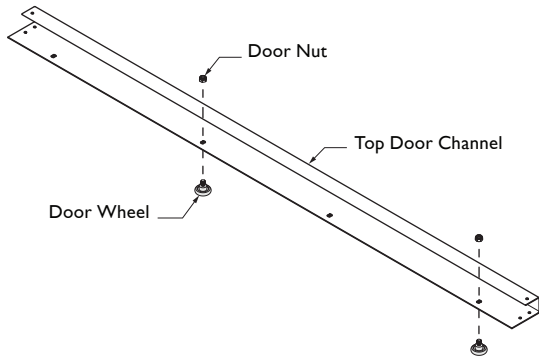

Figure 4.1

Fit the two Handle Mounts in the Vertical Door Channel (Figure 4.2). The two Handle Mounts are the same component, so can be inserted in either order.

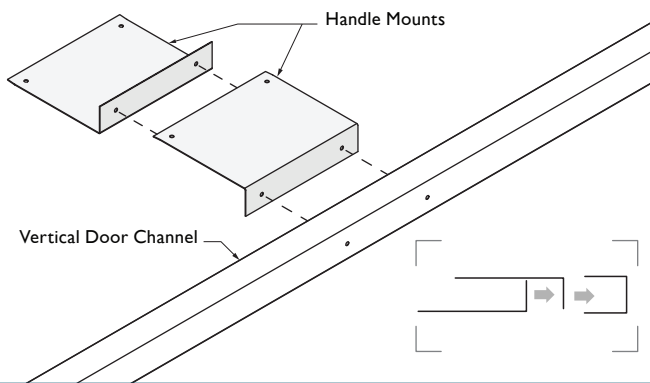

Figure 4.2

Fasten the Handle Mounts through the pilot holes in the Vertical Door Channel with two 10x16 wafer screws (Figure 4.3).

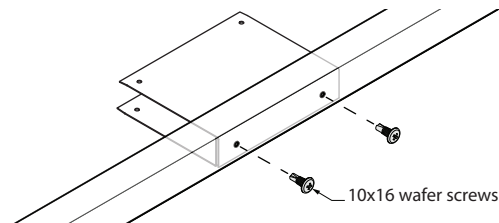

Figure 4.3

Lay out sheets onto trestles/ blocks. Refer to Figure 2.2 for lapping details. Fit the Vertical Door Channels over the side of the door sheets, then fit the Top and Bottom Door Channels over the door sheet ends.

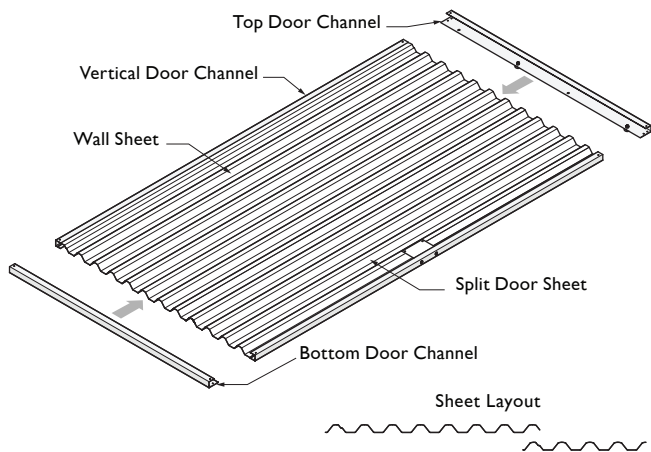

Figure 4.4

Ensure the lip of the Top and Bottom Door Channels fit over the Vertical Door Channels (Figure 4.5).

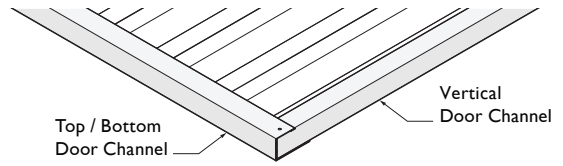

Figure 4.5

Fasten one 10x16 wafer screw through the pilot holes in the corner of each Top & Bottom Channel (Figure 4.6).

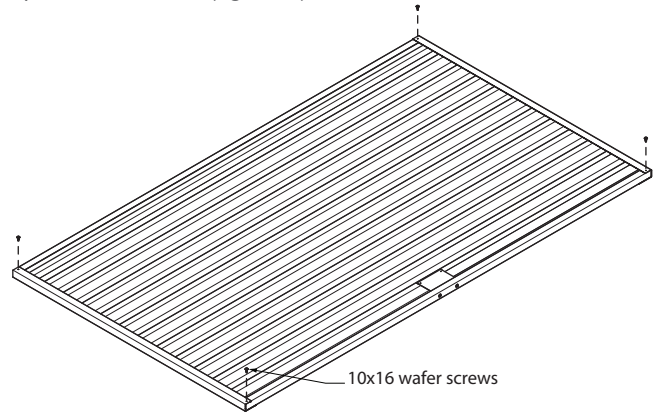

Figure 4.6

Ensure the Door is square. Check the diagonal measurements from corner to corner of the door (dashed lines, Figure 4.7). The diagonal measurements should be equal for the door to be square.

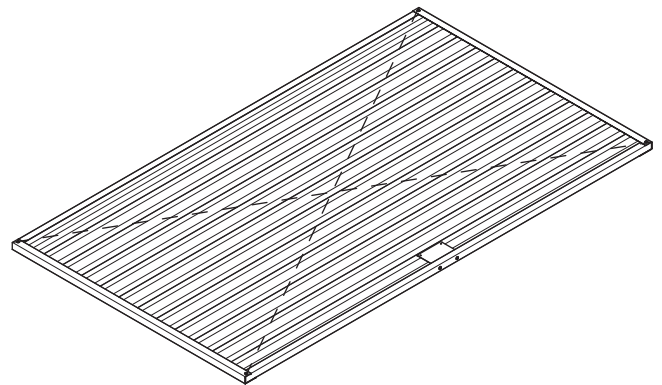

Figure 4.7

Set the door in the square position by fastening two 10x16 wafer screws through the pilot holes on the underside of each corner (Figure 4.8).

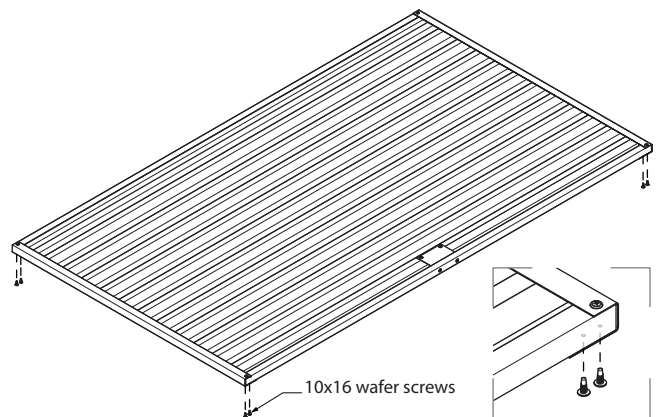

Figure 4.8

Crest-fix 10x16 wafer screws through the Top Door Channel and into the ridges either side of the Door Rollers (Figure 4.9).

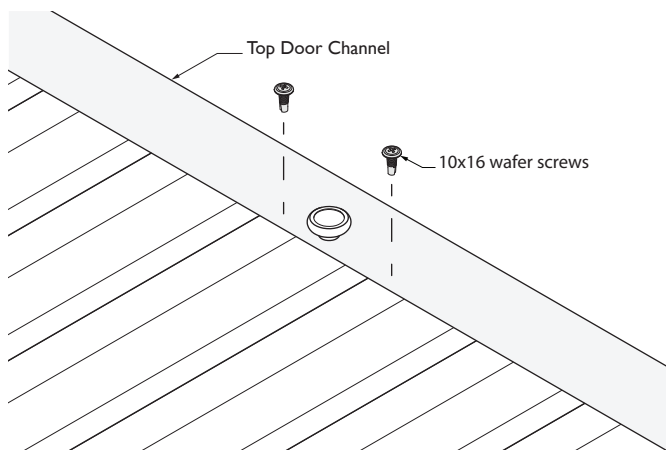

Figure 4.9

Crest-fix two 10x16 wafer screws through pilot holes of the Handle Mounts into the Wall Sheet (Figure 4.10).

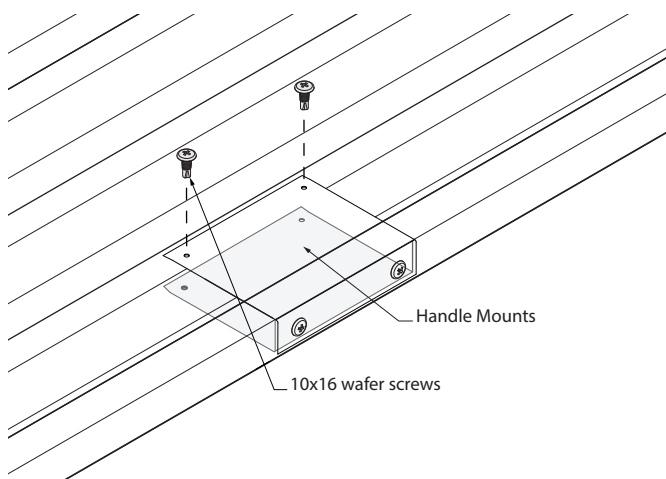

Figure 4.10

A coloured rivet should be used to join the overlap of sheets together (Refer Figure 2.6).

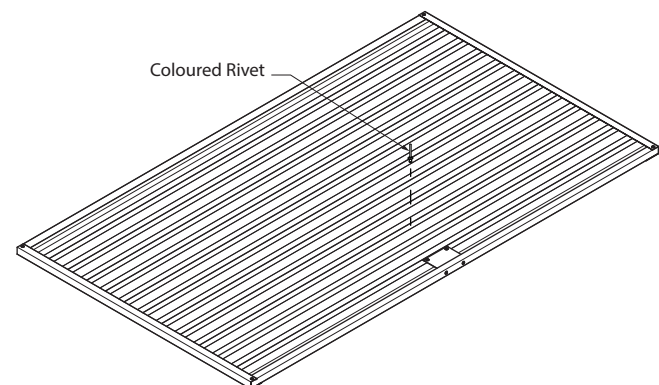

Figure 4.11

Second Wall Assembly

A second Wall Assembly must be made. The second assembly is a mirrored version of the first assembly.

Fix Door Wheels to the Top Door Channel using Door Nuts (Figure 4.12).

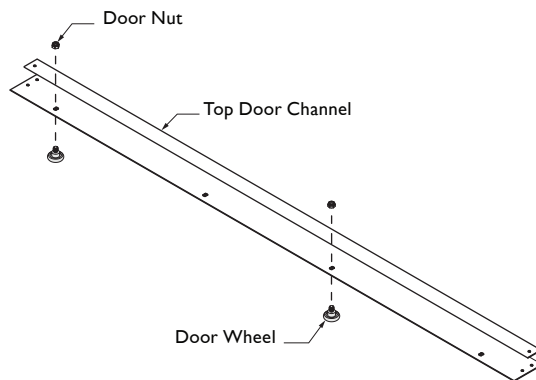

Figure 4.12

Assemble the Handle Mounts as per Figure 4.2-4.3.

Lay out sheets onto trestles/ blocks. Refer to figure 2.2 for lapping details. Fit the Vertical Door Channels over the side of the Door Sheets. Fit the Top and Bottom Door Channels at opposite ends to the first door assembly.

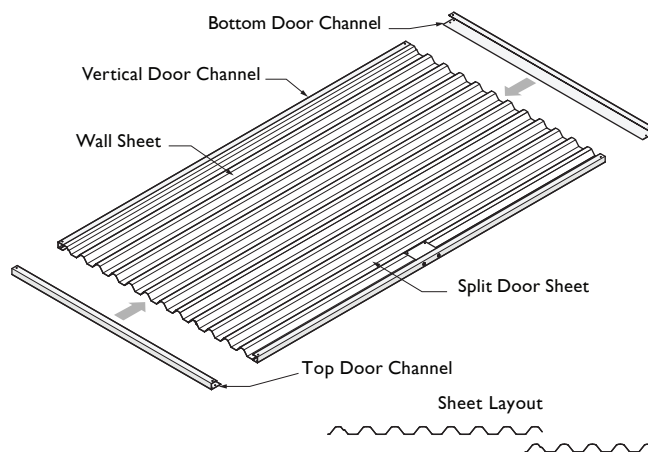

Figure 4.13

Follow all of the remaining steps from 4.5-4.11 to complete the second door assembly.

ERECTING WALL ASSEMBLIES

The wall assemblies can now be joined together. Wall Assemblies should be erected and joined together in the order indicated by the numbered arrows below (Figure 5.0).

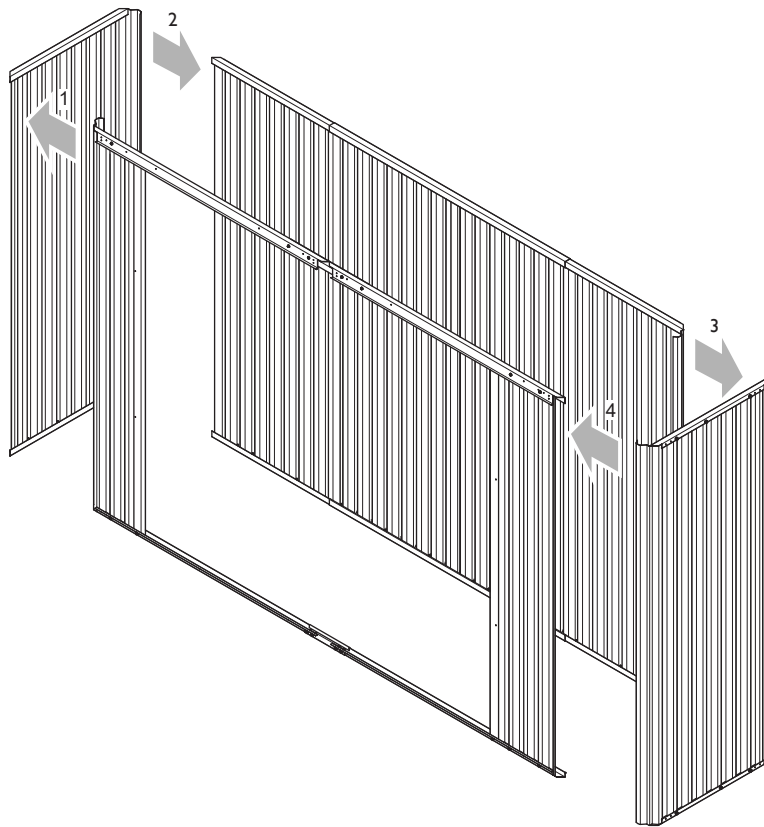

Figure 5.0

Fit the Corner of the Front Wall over the left side Wall Sheet (Figure 5.1).

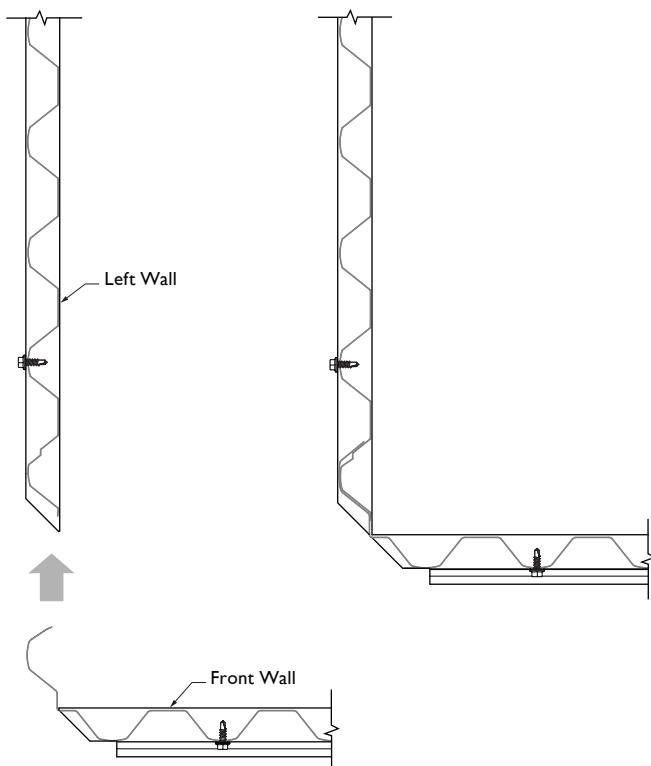

Figure 5.1

Fit the Corner Bracket over the Top Wall Channels. Ensure the pilot holes of the Corner Bracket and Top Wall Channels line up (Figure 5.2).

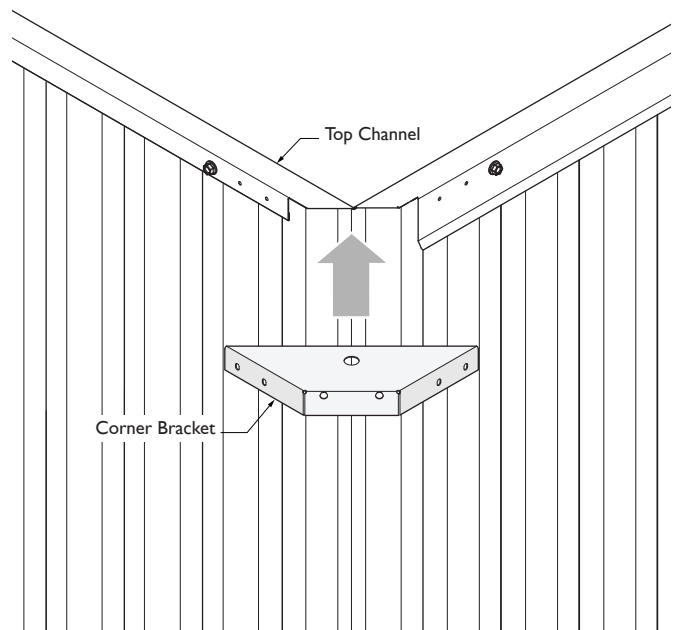

Figure 5.2

Fasten through the Corner Bracket pilot holes and into the Top Channels using 10x16 self-drilling screws (Figure 5.3).

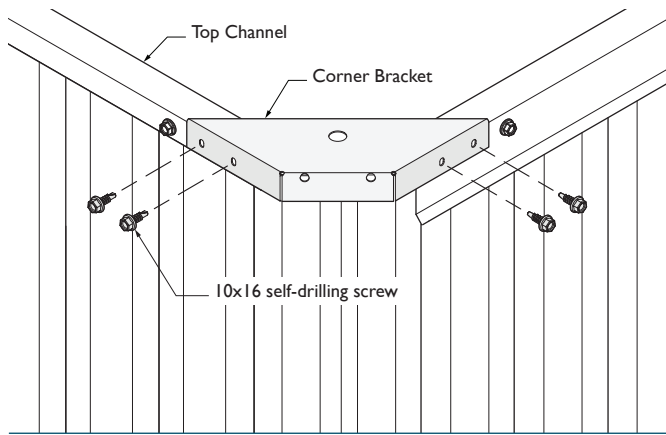

Figure 5.3

Fit the Remaining Wall Assemblies as per Figure 5.1 - 5.3.
Fit the Bottom Corner Brackets of all four corners over the Bottom Wall Channels. Fasten through the Corner Bracket pilot holes and into the Door Channels using 10x16 self-drilling screws (Figure 5.4).

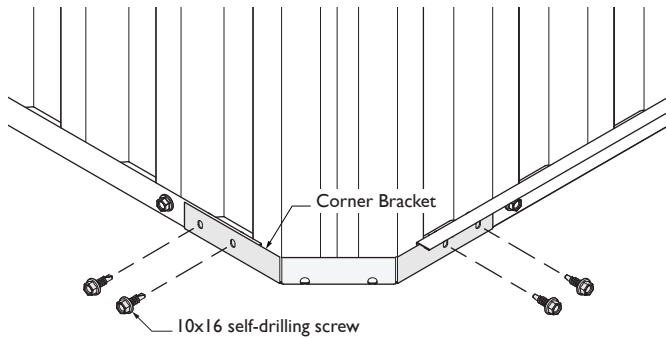

Figure 5.4

Fasten two 10x16 self-drilling screws through pilot holes in each Door Jamb and into the Wall Sheets (Figure 5.5).

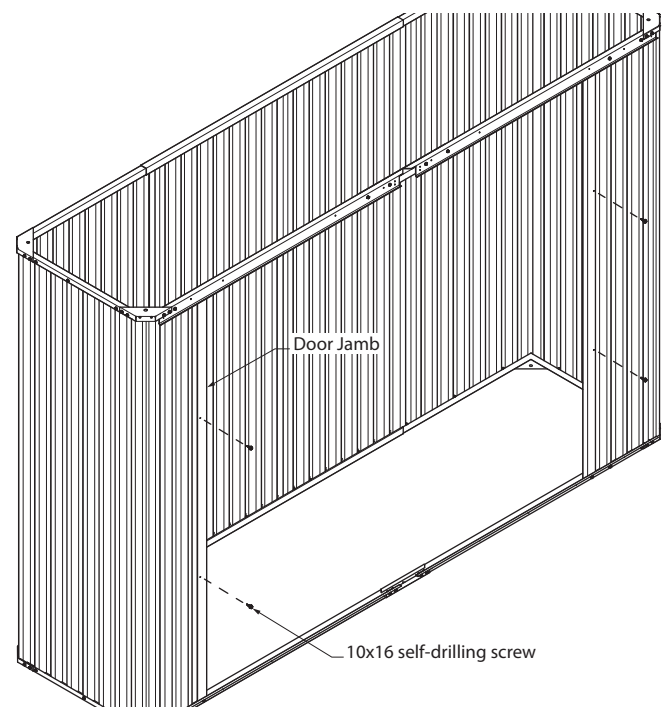

Figure 5.5

Fit the two Barge Supports over the Sliding Rail. Fasten 10x16 self-drilling screws through the two outer pilot holes of the Barge Supports and into the Sliding Rail (Figure 5.6).

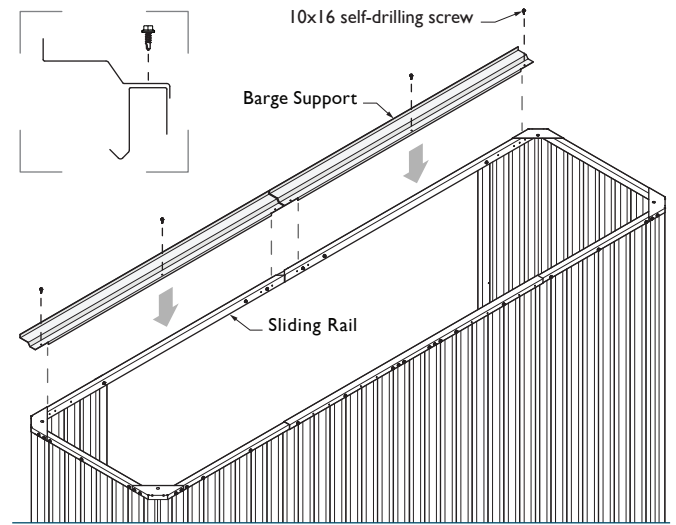

Figure 5.6

Fit the two Runner Rails over the Bottom Channels. Fasten 10x16 self-drilling screws through the two end pilot holes of both Runner Rails and into the Bottom Channels (Figure 5.7).

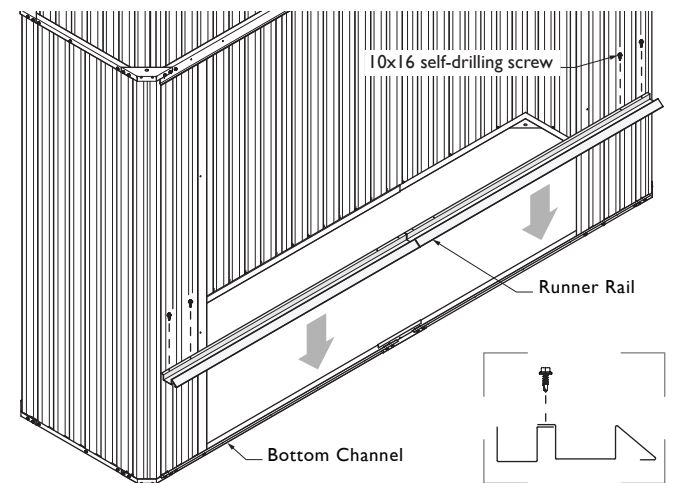

Figure 5.7

Fasten the Door Shrouds to the back face of the Runner Rails with two 10x16 self-drilling screws (Figure 5.8).

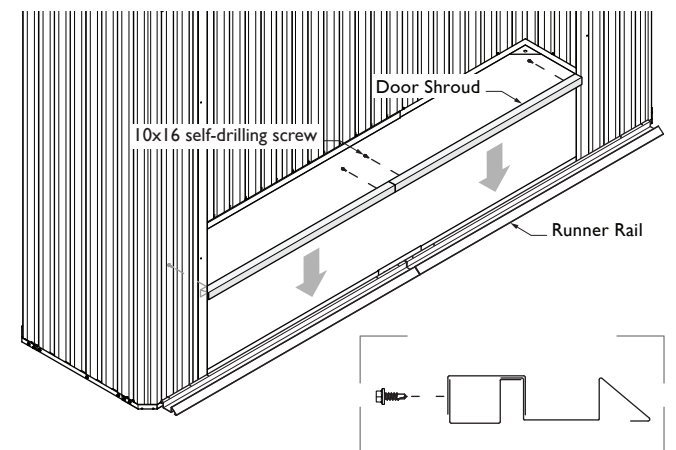

Figure 5.8

Check the walls are square. Check the diagonal measurements from corner to corner (dashed lines, Figure 5.9). The diagonal measurements should be equal for the walls to be square.

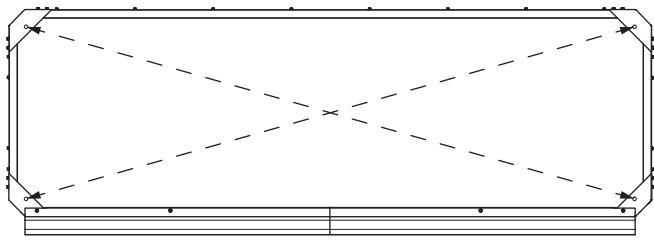

Figure 5.9

Using the Corner Bracket pilot holes as a guide, drill holes in all four corners with a 10mm masonry drill bit. Secure all four Bottom Corner Brackets to the concrete base with M8x47 Masonry Anchors.

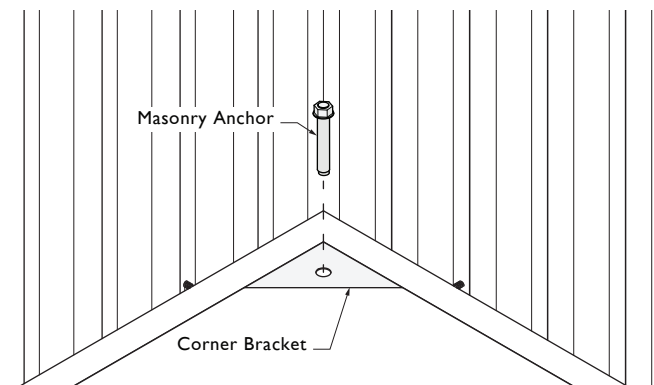

Figure 5.10

Fasten one 10x16 self-drilling screw through each Hold Down Lug into the Bottom Channel and Wall Sheet. Fix Hold Down Lugs to the concrete base with M8x47 Masonry Anchors. Refer to Figure 5.12 for Hold Down Lug spacings.

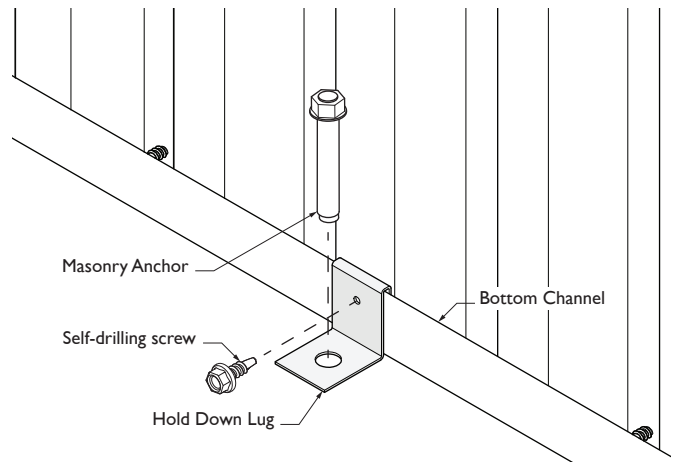

Figure 5.11

The maximum spacing allowed between anchor points is determined by the wind classification assigned to the location of your Handy-Mate. If required, refer to your local council for advice on the wind classification of your location.

N1 / N2 wind classifications = One Hold Down Lug at the midpoint of front and rear walls

N3 wind classifications = Two Hold Down Lugs equally spaced along the front and rear walls

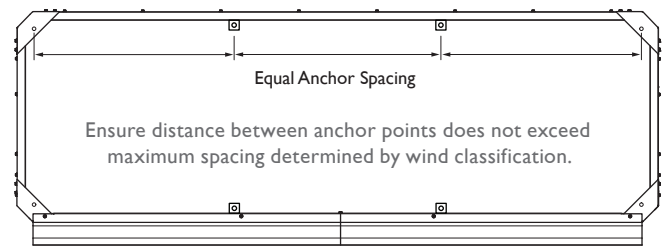

Figure 5.12

ROOF ASSEMBLY

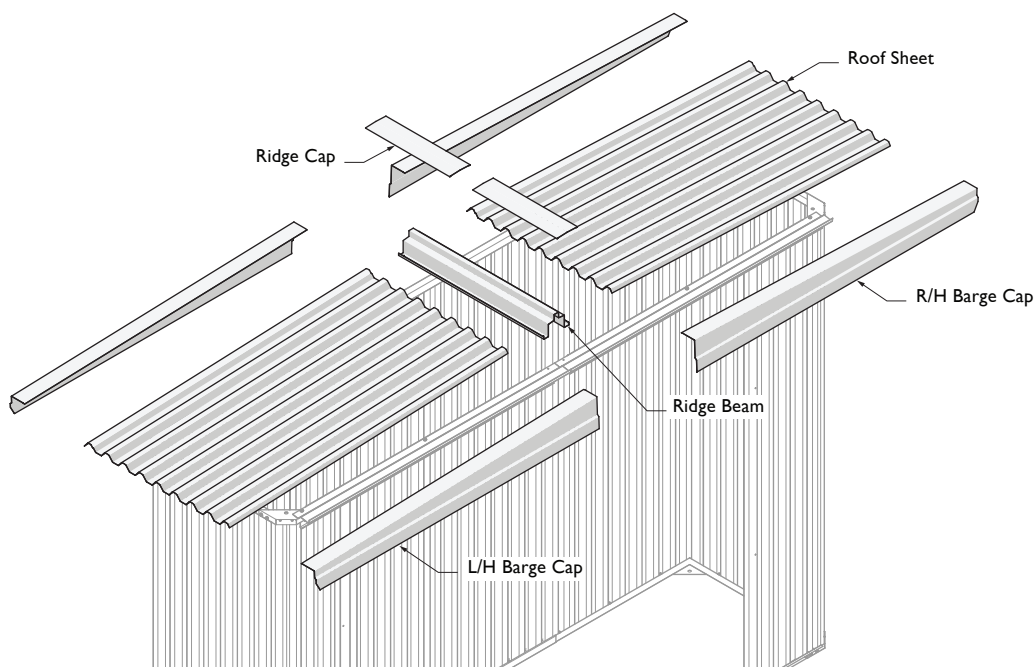

Figure 6.0

Find the centre point of the shed by halving its overall width. Align the centre of the Ridge Beam along this point (Figure 6.1).

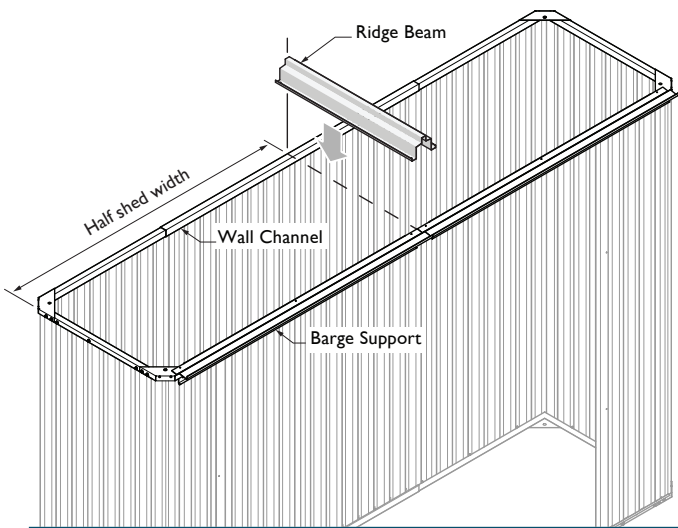

Figure 6.1

Align the end of the Ridge Beam with the step of the Barge Support. Fasten the Ridge Beam to the Barge Supports using two 10x16 self-drilling screws through pilot holes in both ends (Figure 6.2).

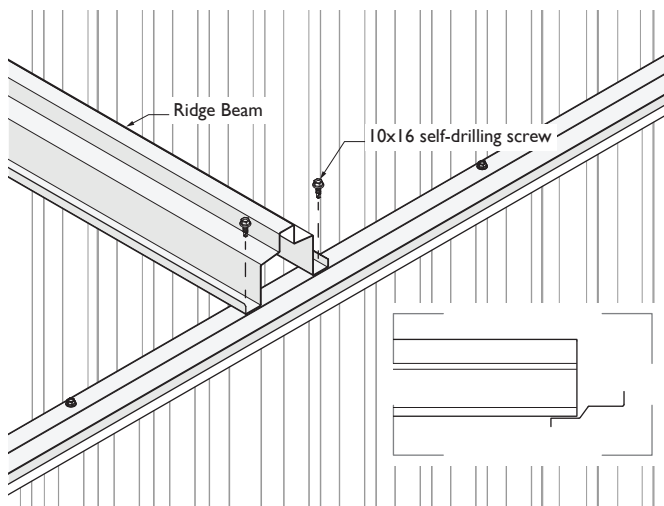

Figure 6.2

Use an adjustable spanner to turn up the pans at the ridge end of the roofing sheets. This will prevent water flowing back under the sheet (Figure 6.3).

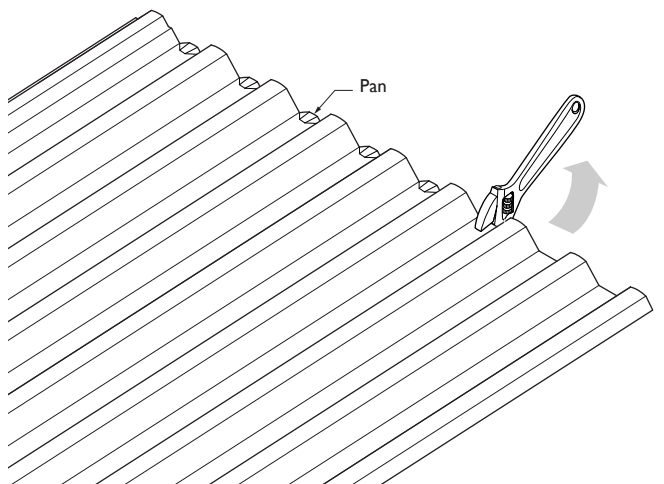

Figure 6.3

Lay the first Roof Sheet onto the Ridge Beam and Wall channel. (Figure 6.4).

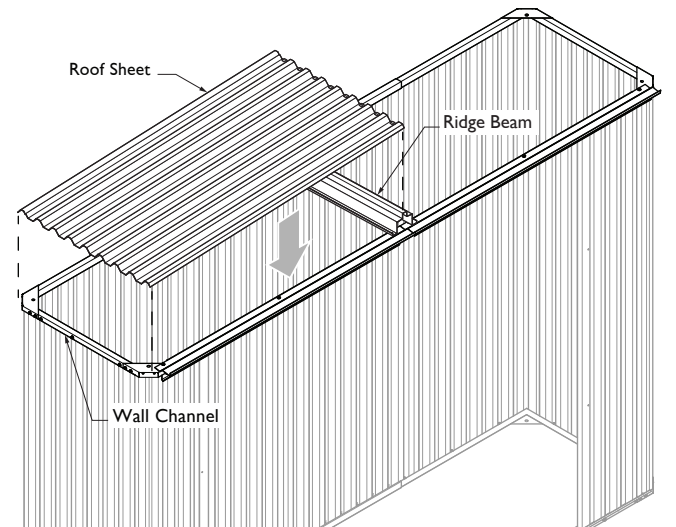

Figure 6.4

Position the middle of the Roof Sheet crest in-line with the end of the Ridge Beam (Figure 6.5). Ensure the under-lap end of the Roof Sheet is facing towards the Rear Wall.

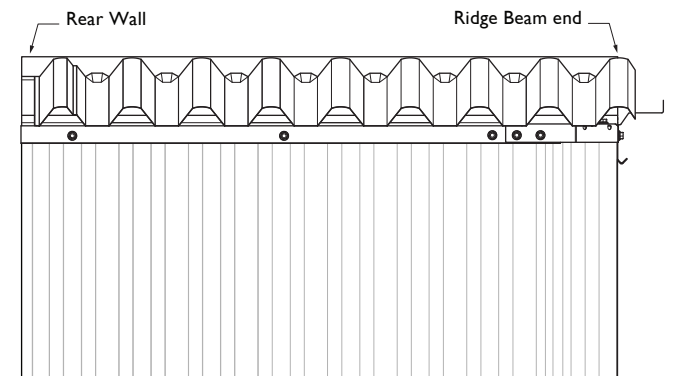

Figure 6.5

Lay the Roof Sheet hard against the step of the Ridge Beam. Fasten three 10x16 self-drilling screws with neo washers through the pans of the Roof Sheet and into the Ridge Beam (Figure 6.6).

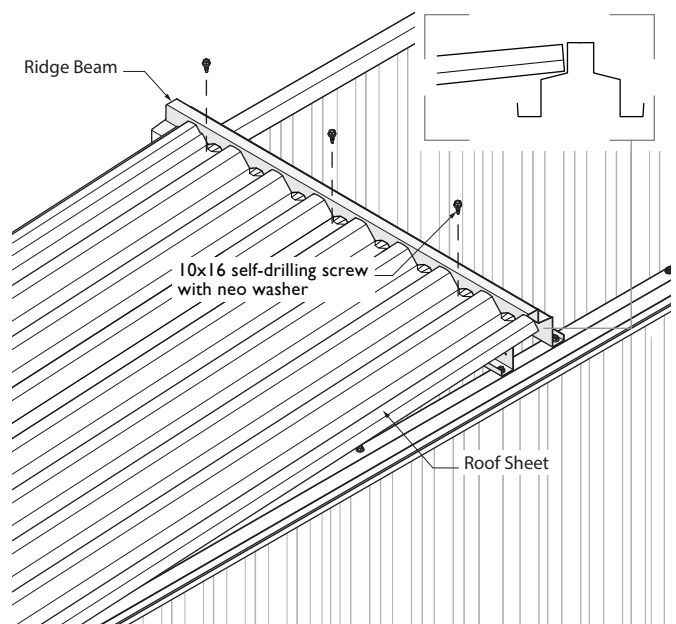

Figure 6.6

Pan fix three 10x16 self-drilling screws with neo washers through the Roof Sheet pans and into the Wall Channel (Figure 6.7).

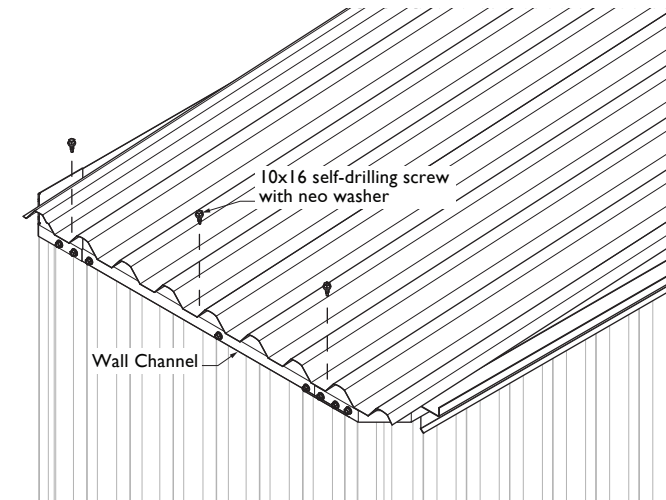

Figure 6.7

Install the opposing side Roof Sheets as per previous steps (Figure 6.8).

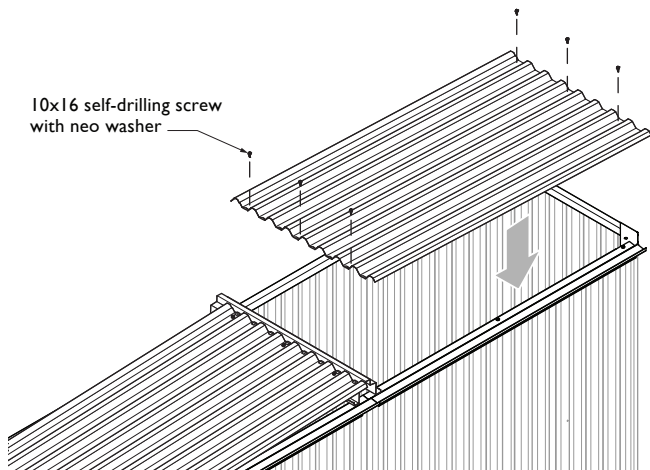

Figure 6.8

Position the Ridge Caps over the Ridge Beam. The outside edge of the Ridge Caps should line up with the outer faces of the Barge Support. Fasten the Ridge Caps to the Ridge Beam using 10x16 self-drilling screws with neo washers, starting 100mm from the Ridge Cap ends (Figure 6.9).

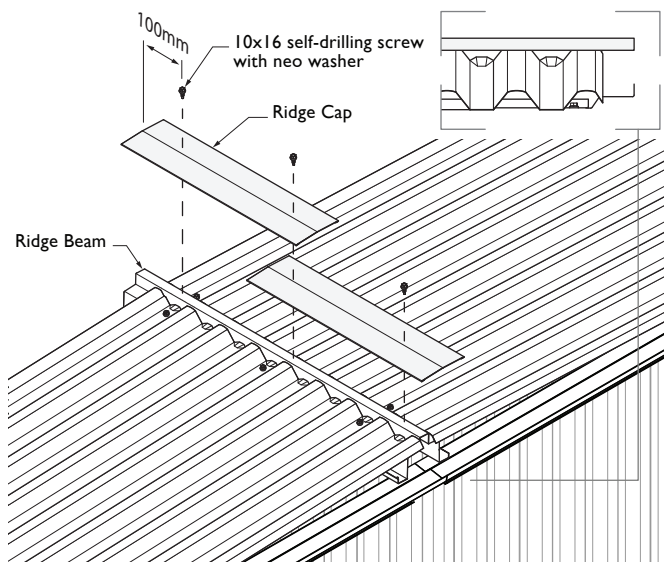

Figure 6.9

Slide the Doors into the Sliding and Runner Rails (Figure 6.10).

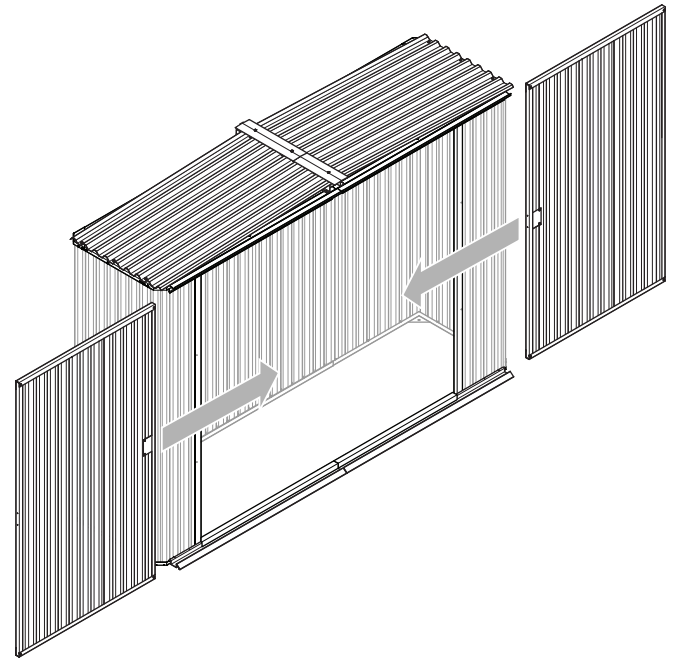

Figure 6.10

The Door Roller should fit into the Sliding Rail at the top. The bottom of the Door should fit into the Runner Rail at the bottom (Figure 6.11).

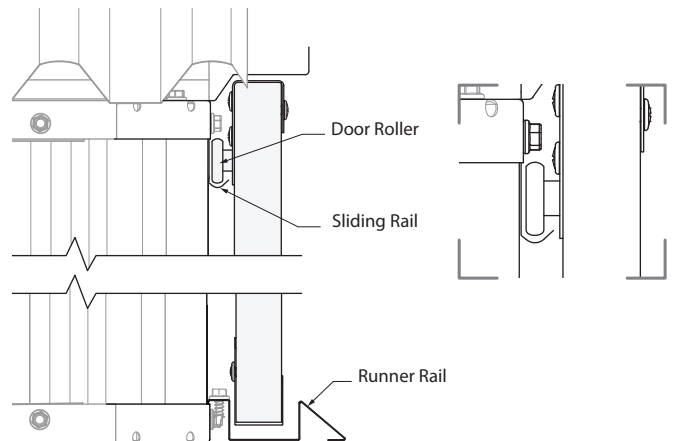

Figure 6.11

Fasten Door Stops through pilot holes in the left hand Sliding Rail with 10x22 wafer-head screws (Figure 6.12). Fasten two Door Stops to the right hand Sliding Rail in the same manner.

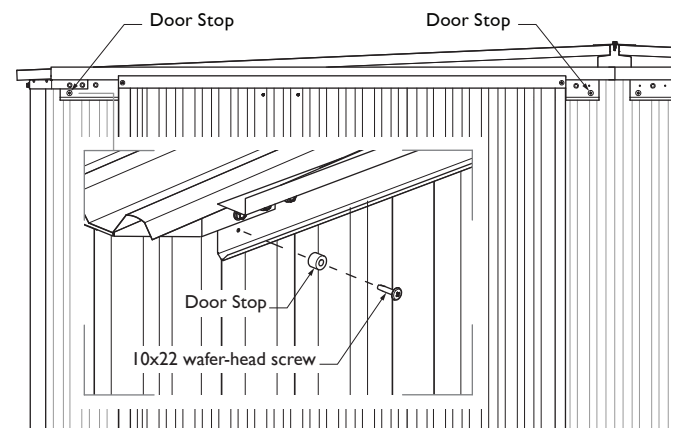

Figure 6.12

Align the Padbolt along the Door edge. Fasten the Padbolt to the Door with two 10x16 self-drilling screws (Figure 6.13).

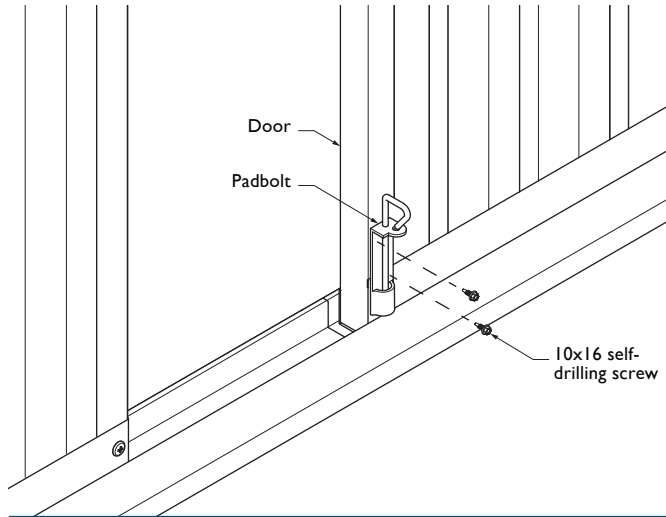

Figure 6.13

Align the Door edge with the meeting point of the Runner Rails (middle point of the shed). Mark the point where the Padbolt shaft touches the Door Shroud (Figure 6.14).

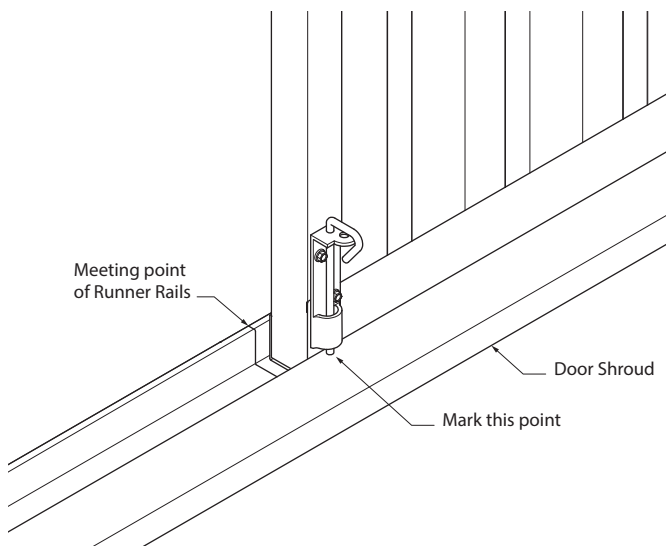

Figure 6.14

Drill a 12mm hole through the Door Shroud and Runner Rail at the point marked in Figure 6.14 (Figure 6.15).

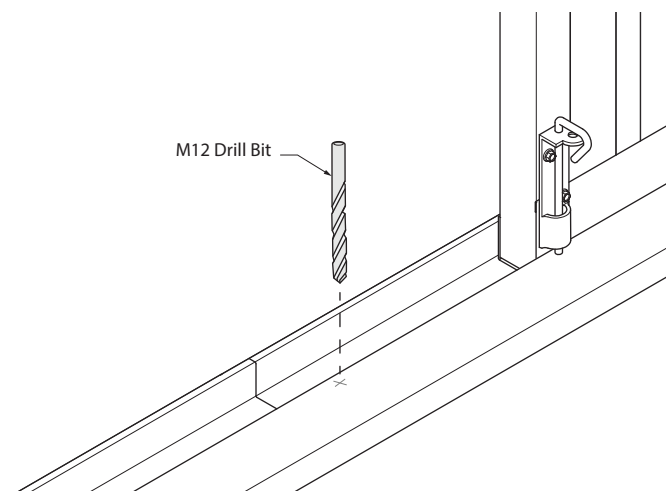

Figure 6.15

Position the Staple against the Handle Mount. Fix in place with four 10x16 wafer-head screws (Figure 6.16).

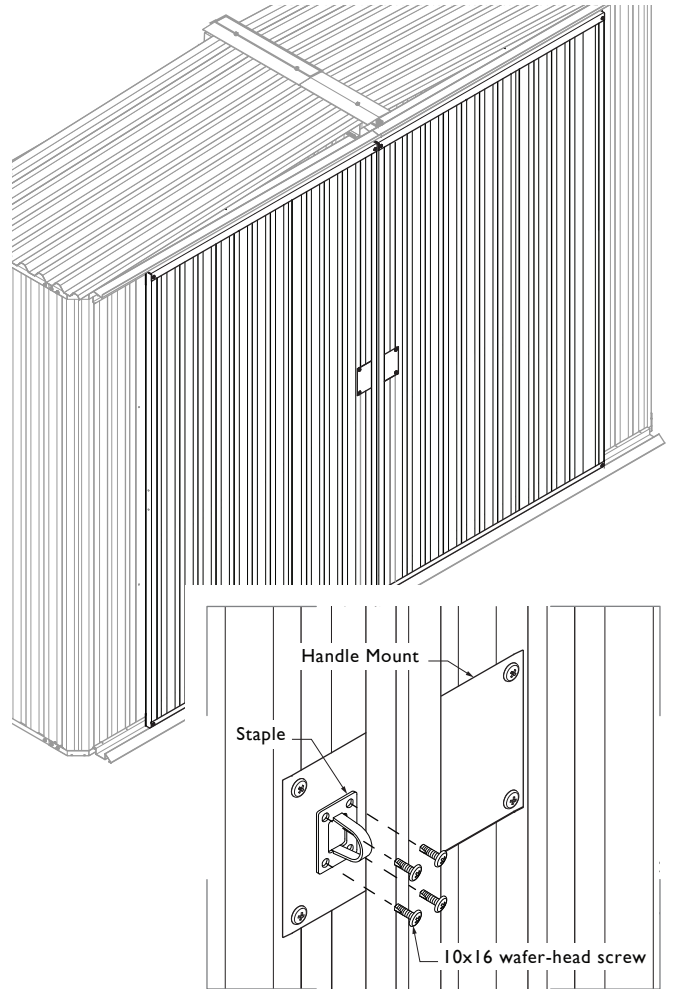

Figure 6.16

Locate the correct position of the Hasp by fitting the Hasp slot over the Staple. Position the Hasp against the Handle Mount. Fix the Hasp to the Handle Mount with three 10x16 wafer-head screws (Figure 6.17).

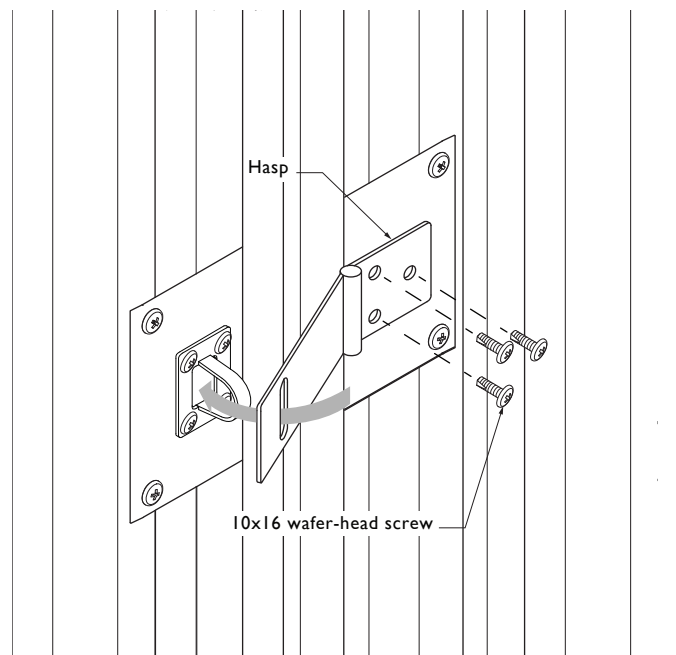

Figure 6.17

Place the Left & Right Barge Caps over the Roof Sheets at the front of the shed. The front face of the Barge Caps should fit up against the Barge Support (Figure 6.18).

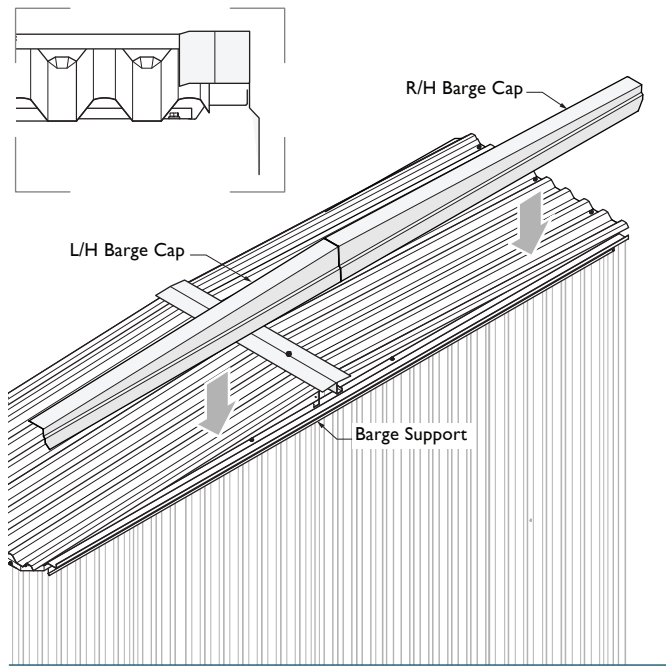

Figure 6.18

The ends of each Barge Cap must align with the ends of the Roof Sheets. Fasten two coloured 10x25 self-drilling screws with neo washers through the front face of each Barge Cap into the Barge Support.

Fasten two coloured 10x25 self-drilling screws with neo washers through the top of each Barge Cap and into the crests of the Roof Sheets (Figure 6.19).

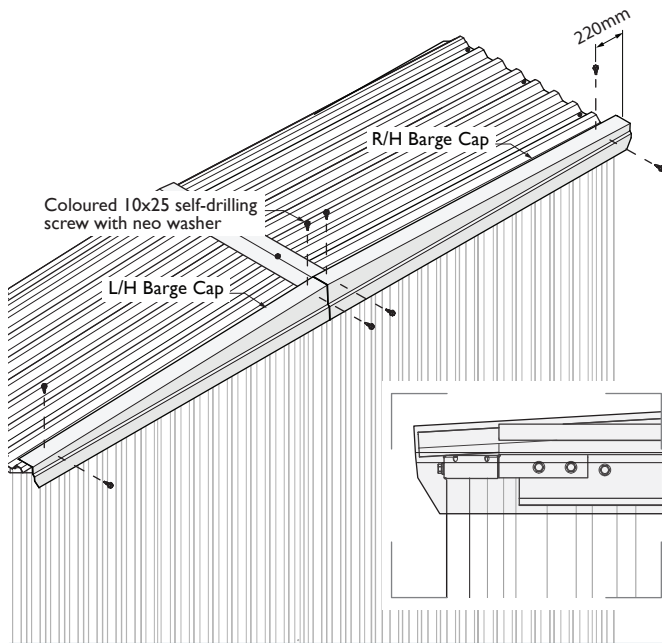

Figure 6.19

Place the remaining left & right Barge Caps over the Roof Sheets at the rear of the shed. Align the ends of each Barge Cap with the ends of the Roof Sheets.

Fasten two coloured 10x25 self-drilling screws with neo washers through the front face of each Barge Cap into the Wall Channel.

Fasten two coloured 10x25 self-drilling screws with neo washers through the top of each Barge Cap and into the crests of the Roof Sheets (Figure 6.20).

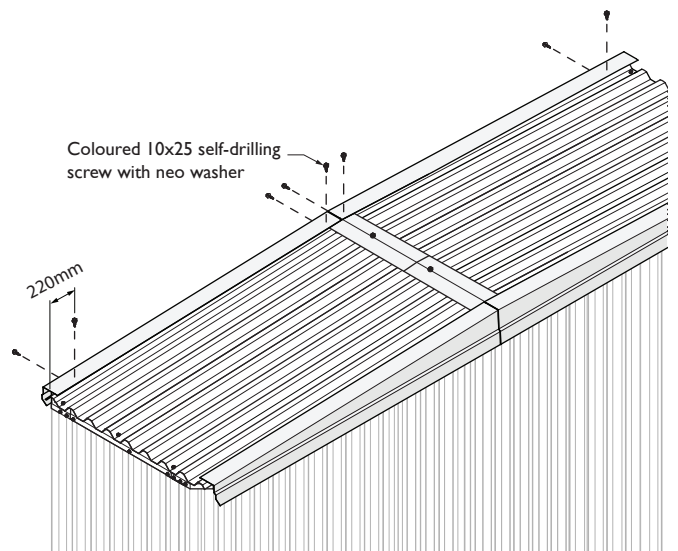

Figure 6.20

WINDOW INSTALLATION

Stratco Shed Windows are an optional add-on, available in both Louvre and Sliding variations. Installation methods are identical for each window type. Windows can only be installed in the Rear Wall (not Side Walls or Door Walls).

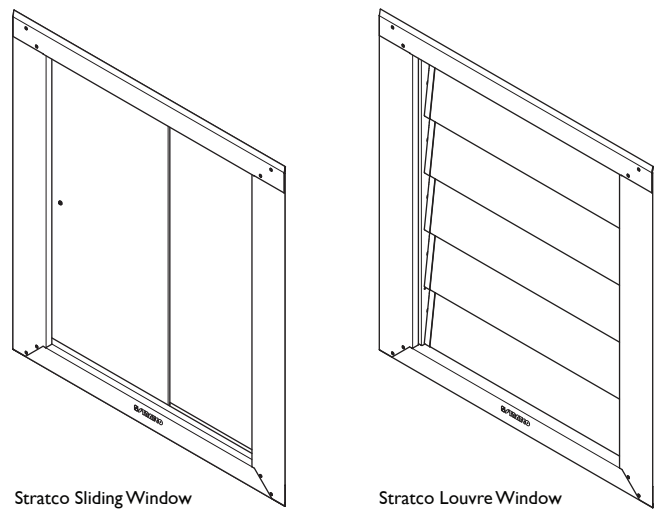

Figure 7.0

Lay the Wall Sheet on trestles or blocks. Mark and cut 750mm from the end of the Wall Sheet (Figure 7.1).

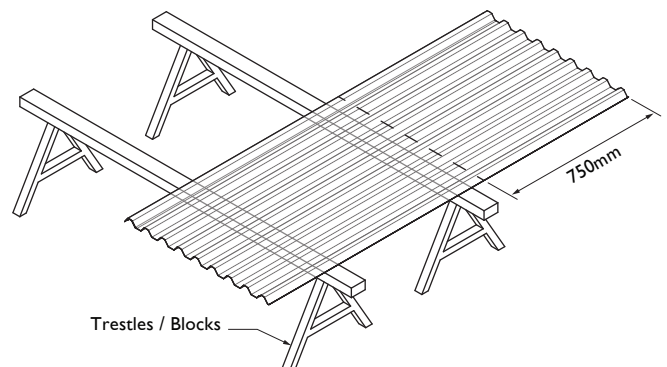

Figure 7.1

Assemble the Rear Wall as per Figure 2.0-2.6 of "Rear Wall Assembly".

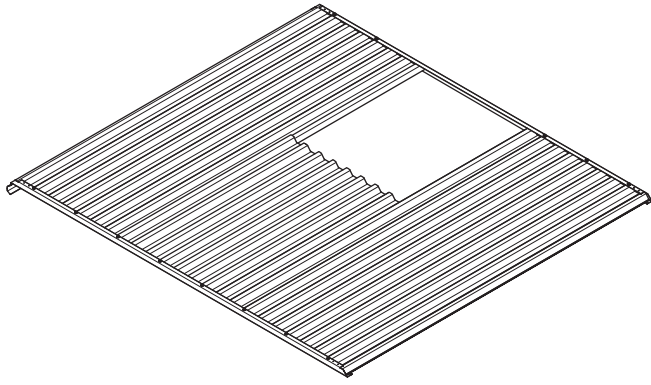

Figure 7.2

Fit the window within the opening. Ensure the top lip of the window is fitted between the Wall Channel and Wall Sheets. A minimum of four evenly spaced rivets must be used along each side of the window frame. All fasteners must be fixed through the crests of the Wall Sheets (Figure 7.3).

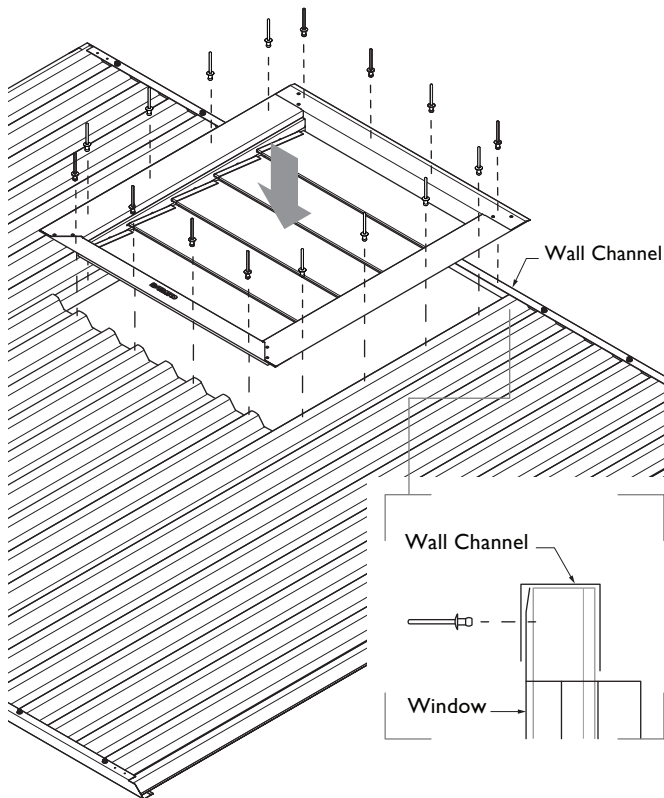

Figure 7.3

The window flashing must be fitted from the inside of the shed. Fit the short face of the flashing between the window and the cut edge of the Wall Sheet.

Secure the flashing to the Wall Sheet with four evenly spaced rivets. Ensure all rivets are crest-fixed through to the sheets (Figure 7.4).

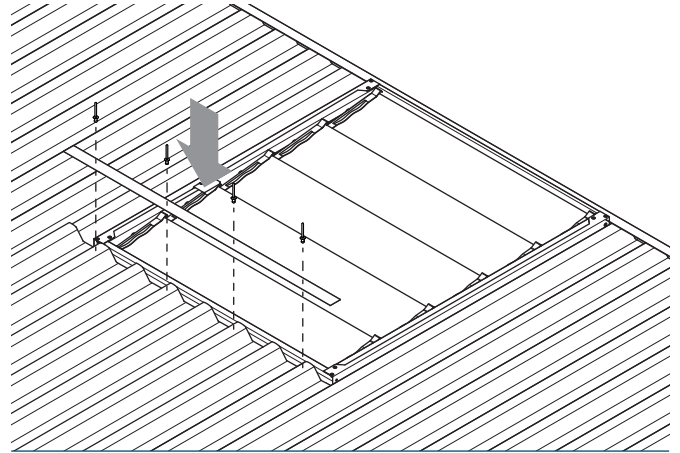





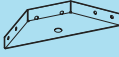













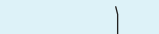
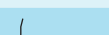



Figure 7.4

SHED MAINTENANCE







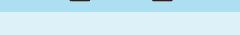
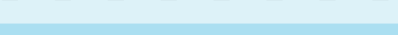
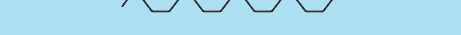



Your Stratco Handi-Mate™ Shed will maintain its good looks for even longer with a simple wash and wipe down. Cleaning should be performed as often as is required to remove any dirt, salt and pollutants.

Stratco Handi-Mate™ Sheds are produced from the highest quality materials and will provide many years of service. Refer to the 'Selection Use and Maintenance' brochure for more information on how to get the best out of your product.

COMPONENT INDEX

PROFILE	DESCRIPTION	PRODUCT CODE
	Hasp & Staple	PM-10873
	Pad Bolt	PM-10874
	Handle Mount	HMDM
	Corner Bracket	HMCB
	Door Jamb	HMDJ
	Door Shroud	HMDSHDRBO
	Top Door Channel	HMDCTO
	Bottom Door Channel	HMDCBO
	Vertical Door Channel	HMDCVE
	Wall Channel	HMWC
	Bottom Channel	HMBR
	Runner Rail	HMRRBO
	Sliding Rail	HMSR
	Sliding Rail Joiner	HSRJGA
	Ramp Channel Joiner	HRCJGA
	Barge Support	HMBS
	Barge Cap - Left Hand Side	HMBCHDRL
	Barge Cap - Right Hand Side	HMBCHDRR
	Ridge Cap	HMRC
	Ridge Beam	HMRB
	Roof Sheet	SSPHMRS
	Split Wall Sheet	SSPHMSW
	Split Door Sheet	SSPHMSD
	Split Corner Wall Sheet	SSPHMSWCNR
	Corner Wall Sheet	SSPHMWSCNR
	Wall Sheet	SSPHMWS

COMPONENT INDEX

PROFILE	DESCRIPTION	PRODUCT CODE
	Hold Down Lug	HMHL
	Door Wheel	HMDW
	Door Stop	HMSS
	Door Nut	HMNN6
	Masonry Anchor	MAA847
	Rivet	RIV4-3
	16mm Wafer Head Screw	WTK1016
	22mm Wafer Head Screw	WTK1022
	16mm Self-Drilling Screw	TEKNNW1016
	16mm Self-Drilling Screw Neo Washer	TEK1016
	25mm Self-Drilling Screw Neo Washer	TEK1025
	Fasteners Kit	HMSKHSD



« Scan this QR code with your smart phone to find a Stratco near you.
 QUEENSLAND • NEW SOUTH WALES • VICTORIA
 AUSTRALIAN CAPITAL TERRITORY • SOUTH AUSTRALIA
 WESTERN AUSTRALIA • NORTHERN TERRITORY

All brands and logos/images accompanied by ® or ™ are trade marks of Stratco (Australia) Pty Limited.

Ph: 1300 155 155
stratco.com.au